



OWNER'S MANUAL

XJR1300

XJR1300S

5WM-28199-21



INTRODUCTION

EAU10100

Welcome to the Yamaha world of motorcycling!

As the owner of the XJR1300, you are benefiting from Yamaha's vast experience and newest technology regarding the design and manufacture of high-quality products, which have earned Yamaha a reputation for dependability.

Please take the time to read this manual thoroughly, so as to enjoy all advantages of your XJR1300. The owner's manual does not only instruct you in how to operate, inspect and maintain your motorcycle, but also in how to safeguard yourself and others from trouble and injury.



In addition, the many tips given in this manual will help keep your motorcycle in the best possible condition. If you have any further questions, do not hesitate to contact your Yamaha dealer.

The Yamaha team wishes you many safe and pleasant rides. So, remember to put safety first!

IMPORTANT MANUAL INFORMATION

EAU10150

Particularly important information is distinguished in this manual by the following notations:

	The Safety Alert Symbol means ATTENTION! BECOME ALERT! YOUR SAFETY IS INVOLVED!
	Failure to follow WARNING instructions could result in severe injury or death to the motorcycle operator, a bystander, or a person inspecting or repairing the motorcycle.
	A CAUTION indicates special precautions that must be taken to avoid damage to the motorcycle.
NOTE:	A NOTE provides key information to make procedures easier or clearer

NOTE:

- This manual should be considered a permanent part of this motorcycle and should remain with it even if the motorcycle is subsequently sold
- Yamaha continually seeks advancements in product design and quality. Therefore, while this manual contains the most current product information available at the time of printing, there may be minor discrepancies between your motorcycle and this manual. If you have any questions concerning this manual, please consult your Yamaha dealer.

 **WARNING**

EWA10030

PLEASE READ THIS MANUAL CAREFULLY AND COMPLETELY BEFORE OPERATING THIS MOTORCYCLE.

IMPORTANT MANUAL INFORMATION

EAU10200

**XJR1300S
OWNER'S MANUAL
©2003 by Yamaha Motor Co., Ltd.
1st edition, September 2003
All rights reserved.
Any reprinting or unauthorized use
without the written permission of
Yamaha Motor Co., Ltd.
is expressly prohibited.
Printed in Japan.**

TABLE OF CONTENTS

SAFETY INFORMATION	1-1	Adjusting the shock absorber assemblies	3-16	Adjusting the engine idling speed	6-12
Location of important labels	1-5	Luggage strap holders	3-17	Adjusting the throttle cable free play	6-12
DESCRIPTION	2-1	Sidestand	3-18	Adjusting the valve clearance	6-13
Left view	2-1	Ignition circuit cut-off system	3-18	Tires	6-13
Right view	2-2	PRE-OPERATION CHECKS	4-1	Cast wheels	6-15
Controls and instruments	2-3	Pre-operation check list	4-2	Clutch lever free play	6-16
INSTRUMENT AND CONTROL FUNCTIONS	3-1	OPERATION AND IMPORTANT RIDING POINTS	5-1	Adjusting the brake pedal position	6-16
Immobilizer system	3-1	Starting and warming up a cold engine	5-1	Rear brake light switch adjustment	6-17
Main switch/steering lock	3-2	Starting a warm engine	5-2	Checking the front and rear brake pads	6-17
Indicator and warning lights	3-3	Shifting	5-2	Checking the brake and clutch fluid levels	6-18
Speedometer	3-5	Tips for reducing fuel consumption	5-3	Changing the brake and clutch fluids	6-19
Tachometer	3-5	Engine break-in	5-3	Drive chain slack	6-20
Self-diagnosis device	3-5	Parking	5-4	Lubricating the drive chain	6-21
Multi-function display	3-6	PERIODIC MAINTENANCE AND MINOR REPAIR	6-1	Checking and lubricating the cables	6-22
Handlebar switches	3-7	Owner's tool kit	6-1	Checking and lubricating the throttle grip and cable	6-22
Clutch lever	3-8	Periodic maintenance and lubrication chart	6-2	Checking and lubricating the brake and shift pedals	6-22
Shift pedal	3-9	Removing and installing panels	6-5	Checking and lubricating the brake and clutch levers	6-23
Brake lever	3-9	Checking the spark plugs	6-7	Checking and lubricating the centerstand and sidestand	6-24
Brake pedal	3-10	Engine oil and oil filter element	6-8	Checking the front fork	6-24
Fuel tank cap	3-10	Cleaning the air filter element	6-10		
Fuel	3-11	Adjusting the carburetors	6-11		
Catalytic converter	3-12				
Fuel cock	3-12				
Starter (choke) lever	3-13				
Seat	3-14				
Helmet holder	3-14				
Storage compartment	3-15				
Adjusting the front fork	3-15				

TABLE OF CONTENTS

Checking the steering ..	6-25
Checking the wheel bearings ..	6-26
Battery	6-26
Replacing the fuses	6-27
Replacing the headlight bulb ..	6-28
Replacing a tail/brake light bulb	6-30
Replacing a turn signal light bulb	6-30
Replacing the auxiliary light bulb	6-31
Front wheel	6-31
Rear wheel	6-33
Troubleshooting ..	6-34
Troubleshooting chart . . .	6-35

MOTORCYCLE CARE AND

STORAGE	7-1
Care	7-1
Storage	7-3

SPECIFICATIONS

8-1

CONSUMER INFORMATION

9-1

Identification numbers

9-1

Motorcycle noise regulation (for Australia)

9-2

SAFETY INFORMATION

EAU10250

1 MOTORCYCLES ARE SINGLE TRACK VEHICLES. THEIR SAFE USE AND OPERATION ARE DEPENDENT UPON THE USE OF PROPER RIDING TECHNIQUES AS WELL AS THE EXPERTISE OF THE OPERATOR. EVERY OPERATOR SHOULD KNOW THE FOLLOWING REQUIREMENTS BEFORE RIDING THIS MOTORCYCLE

HE OR SHE SHOULD:

- OBTAIN THOROUGH INSTRUCTIONS FROM A COMPETENT SOURCE ON ALL ASPECTS OF MOTORCYCLE OPERATION.
- OBSERVE THE WARNINGS AND MAINTENANCE REQUIREMENTS IN THE OWNER'S MANUAL
- OBTAIN QUALIFIED TRAINING IN SAFE AND PROPER RIDING TECHNIQUES
- OBTAIN PROFESSIONAL TECHNICAL SERVICE AS INDICATED BY THE OWNER'S MANUAL

AND/OR WHEN MADE NECESSARY BY MECHANICAL CONDITIONS.

Safe riding

- Always make pre-operation checks Careful checks may help prevent an accident.
- This motorcycle is designed to carry the operator and a passenger
- The failure of motorists to detect and recognize motorcycles in traffic is the predominating cause of automobile/motorcycle accidents Many accidents have been caused by an automobile driver who did not see the motorcycle. Making yourself conspicuous appears to be very effective in reducing the chance of this type of accident.

Therefore:

- Wear a brightly colored jacket.
- Use extra caution when approaching and passing through intersections, since intersections are the most likely places for motorcycle accidents to occur

- Ride where other motorists can see you Avoid riding in another motorist's blind spot.
- Many motorcycle accidents involve inexperienced operators. In fact, many operators who have been involved in accidents do not even have a current motorcycle license.
 - Make sure that you are qualified and that you only lend your motorcycle to other qualified operators
 - Know your skills and limits Staying within your limits may help you to avoid an accident.
 - We recommend that you practice riding your motorcycle where there is no traffic until you have become thoroughly familiar with the motorcycle and all of its controls.
- Many motorcycle accidents have been caused by error of the motorcycle operator A typical error made by the operator is veering

wide on a turn due to EXCESSIVE SPEED or undercornering (insufficient lean angle for the speed)

- Always obey the speed limit and never travel faster than warranted by road and traffic conditions.
- Always signal before turning or changing lanes. Make sure that other motorists can see you
- The posture of the operator and passenger is important for proper control.
 - The operator should keep both hands on the handlebar and both feet on the operator footrests during operation to maintain control of the motorcycle.
 - The passenger should always hold onto the operator, seat strap, or grab bar, if equipped, with both hands and keep both feet on the passenger footrests
 - Never carry a passenger unless he or she can firmly place both feet on the passenger footrests.
- Never ride under the influence of alcohol or other drugs.

- This motorcycle is designed for on-road use only, therefore, it is not suitable for off-road use

Protective apparel

The majority of fatalities from motorcycle accidents are the result of head injuries. The use of a safety helmet is the single most critical factor in the prevention or reduction of head injuries.

- Always wear an approved helmet.
- Wear a face shield or goggles
Wind in your unprotected eyes could contribute to an impairment of vision which could delay seeing a hazard.
- The use of a jacket, heavy boots, trousers, gloves, etc., is effective in preventing or reducing abrasions or lacerations.
- Never wear loose-fitting clothes, otherwise they could catch on the control levers, footrests, or wheels and cause injury or an accident
- Never touch the engine or exhaust system during or after operation
They become very hot and can

cause burns. Always wear protective clothing that covers your legs, ankles, and feet.

- Passengers should also observe the precautions mentioned above.

Modifications

Modifications made to this motorcycle not approved by Yamaha, or the removal of original equipment, may render the motorcycle unsafe for use and may cause severe personal injury. Modifications may also make your motorcycle illegal to use.

Loading and accessories

Adding accessories or cargo to your motorcycle can adversely affect stability and handling if the weight distribution of the motorcycle is changed. To avoid the possibility of an accident, use extreme caution when adding cargo or accessories to your motorcycle. Use extra care when riding a motorcycle that has added cargo or accessories. Here are some general guidelines to follow if loading cargo or adding accessories to your motorcycle:

SAFETY INFORMATION

Loading

The total weight of the operator, passenger, accessories and cargo must not exceed the maximum load limit of 203 kg (448 lb). When loading within this weight limit, keep the following in mind:

- Cargo and accessory weight should be kept as low and close to the motorcycle as possible. Make sure to distribute the weight as evenly as possible on both sides of the motorcycle to minimize imbalance or instability.
- Shifting weights can create a sudden imbalance. Make sure that accessories and cargo are securely attached to the motorcycle before riding. Check accessory mounts and cargo restraints frequently.
- Never attach any large or heavy items to the handlebar, front fork, or front fender. These items, including such cargo as sleeping bags, duffel bags, or tents, can create unstable handling or slow steering response.

Accessories

Genuine Yamaha accessories have been specifically designed for use on this motorcycle. Since Yamaha cannot test all other accessories that may be available, you must personally be responsible for the proper selection, installation and use of non-Yamaha accessories. Use extreme caution when selecting and installing any accessories.

Keep the following guidelines in mind, as well as those provided under “Loading” when mounting accessories:

- Never install accessories or carry cargo that would impair the performance of your motorcycle. Carefully inspect the accessory before using it to make sure that it does not in any way reduce ground clearance or cornering clearance, limit suspension travel, steering travel or control operation, or obscure lights or reflectors.
- Accessories fitted to the handlebar or the front fork area can create instability due to improper weight distribution or aerodynamic changes. If accessories

are added to the handlebar or front fork area, they must be as lightweight as possible and should be kept to a minimum.

- Bulky or large accessories may seriously affect the stability of the motorcycle due to aerodynamic effects. Wind may attempt to lift the motorcycle, or the motorcycle may become unstable in cross winds. These accessories may also cause instability when passing or being passed by large vehicles.
- Certain accessories can displace the operator from his or her normal riding position. This improper position limits the freedom of movement of the operator and may limit control ability, therefore, such accessories are not recommended.
- Use caution when adding electrical accessories. If electrical accessories exceed the capacity of the motorcycle’s electrical system, an electric failure could result, which could cause a dangerous loss of lights or engine power.

Gasoline and exhaust gas

- GASOLINE IS HIGHLY FLAMMABLE:
 - Always turn the engine off when refueling.
 - Take care not to spill any gasoline on the engine or exhaust system when refueling
 - Never refuel while smoking or in the vicinity of an open flame.
- Never start the engine or let it run for any length of time in a closed area. The exhaust fumes are poisonous and may cause loss of consciousness and death within a short time. Always operate your motorcycle in an area that has adequate ventilation.
- Always turn the engine off before leaving the motorcycle unattended and remove the key from the main switch. When parking the motorcycle, note the following:
 - The engine and exhaust system may be hot, therefore, park the motorcycle in a place where pedestrians or children are not likely to touch these hot areas.
 - Do not park the motorcycle on a slope or soft ground, otherwise it may fall over.
 - Do not park the motorcycle near a flammable source (e.g. a kerosene heater, or near an open flame), otherwise it could catch fire
- When transporting the motorcycle in another vehicle, make sure that it is kept upright and that the fuel cock is turned to “ON” or “RES” (for vacuum type) / “OFF” (for manual type). If it should lean over, gasoline may leak out of the carburetor or fuel tank.
- If you should swallow any gasoline, inhale a lot of gasoline vapor, or allow gasoline to get into your eyes, see your doctor immediately. If any gasoline spills on your skin or clothing, immediately wash the affected area with soap and water and change your clothes

SAFETY INFORMATION

EAU10381

Location of important labels

Please read the following important labels carefully before operating this vehicle.

1

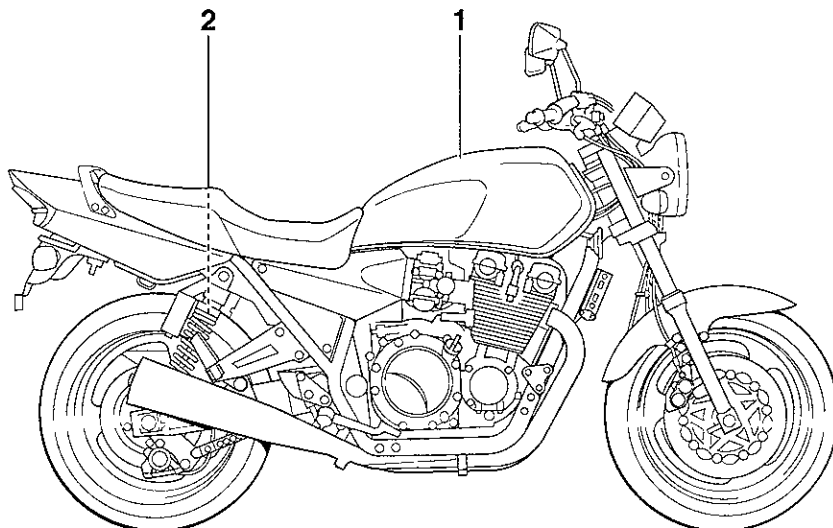

1

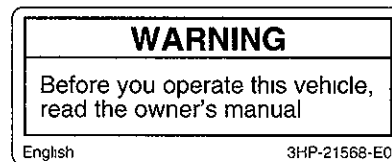

2



Left view

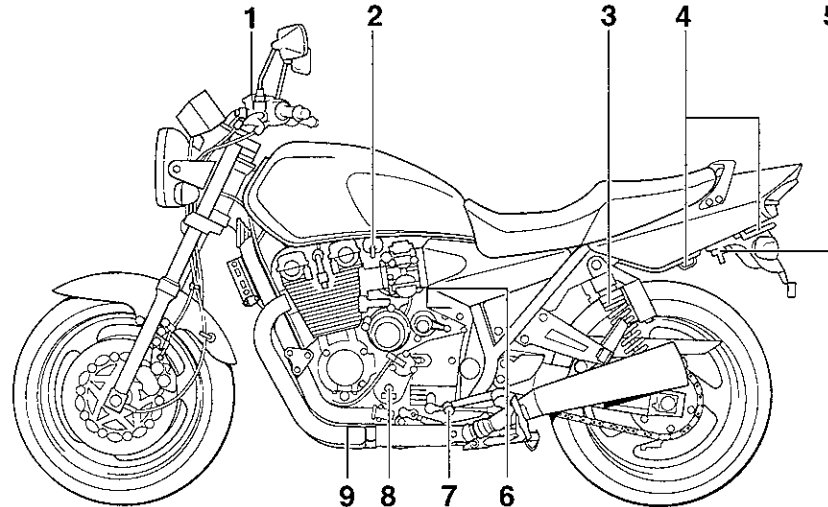

- 1 Clutch fluid reservoir (page 6-18)
- 2 Fuel cock (page 3-12)
- 3 Shock absorber assembly spring preload adjusting ring (page 3-16)
- 4 Luggage strap holder (page 3-17)
- 5 Seat lock/helmet holder (page 3-14/page 3-14)
- 6 Throttle stop screw (page 6-12)
- 7 Shift pedal (page 3-9)
- 8 Engine oil filter element (page 6-8)
- 9 Engine oil drain bolt (page 6-8)

DESCRIPTION

EAU10420

Right view

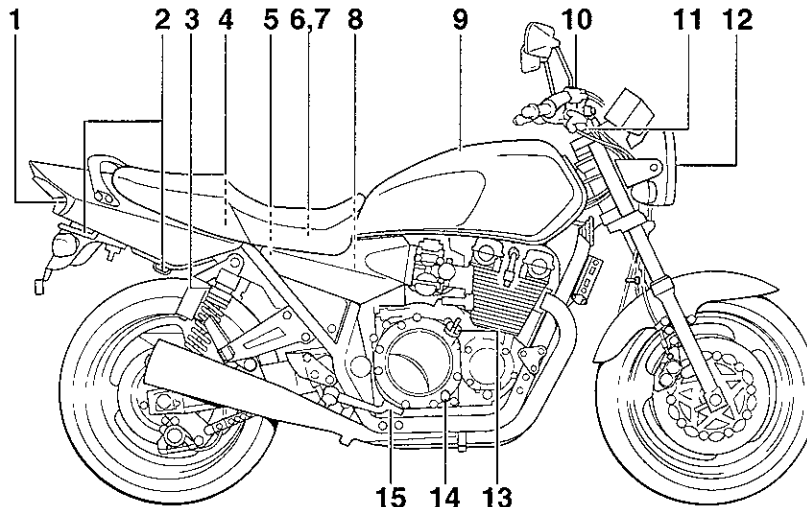

- 1 Tail/brake light (page 6-30)
- 2 Luggage strap holder (page 3-17)
- 3 Shock absorber assembly spring preload adjusting ring (page 3-16)
- 4 Owner's tool kit (page 6-1)
- 5 Rear brake fluid reservoir (page 6-18)
- 6 Fuses (page 6-27)
- 7 Battery (page 6-26)
- 8 Air filter element (page 6-10)
- 9 Fuel tank (page 3-10)
- 10 Front brake fluid reservoir (page 6-18)
- 11 Front fork spring preload adjusting bolt (page 3-15)

- 12 Headlight (page 6-28)
- 13 Engine oil filler cap (page 6-8)
- 14 Engine oil level check window (page 6-8)
- 15 Brake pedal (page 3-10)

Controls and instruments

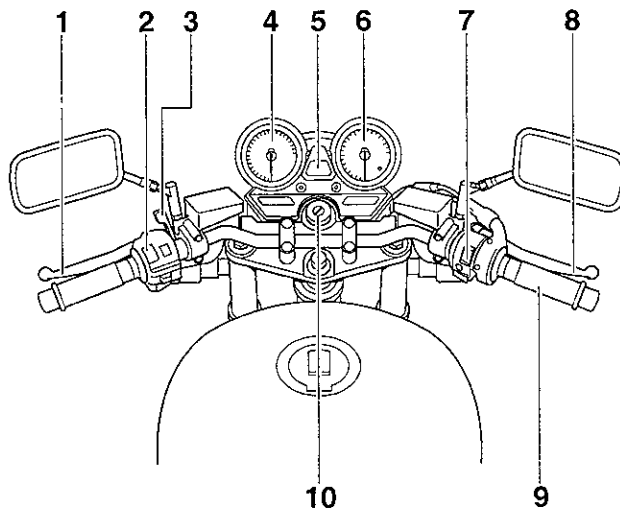

- 1 Clutch lever (page 3-8)
- 2 Left handlebar switches (page 3-7)
- 3 Starter (choke) lever (page 3-13)
- 4 Speedometer (page 3-5)
- 5 Multi-function display (page 3-6)
- 6 Tachometer (page 3-5)
- 7 Right handlebar switches (page 3-7)
- 8 Brake lever (page 3-9)
- 9 Throttle grip (page 6-12)
- 10 Main switch/steering lock (page 3-2)

INSTRUMENT AND CONTROL FUNCTIONS

Immobilizer system

EAU26890

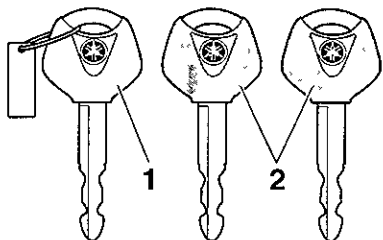

- 1 Code re-registering key (red bow)
2 Standard keys (black bow)

This vehicle is equipped with an immobilizer system to help prevent theft by re-registering codes in the standard keys. This system consists of the following

- a code re-registering key (with a red bow)
- two standard keys (with a black bow) that can be re-registered with new codes
- a transponder (which is installed in the code re-registering key)
- an immobilizer unit
- the ignitor unit

- an immobilizer system indicator light (See page 3-3.)

The key with the red bow is used to register codes in each standard key. Since re-registering is a difficult process, take the vehicle along with all three keys to a Yamaha dealer to have them re-registered. Do not use the key with the red bow for driving. It should only be used for re-registering the standard keys. Always use a standard key for driving.

ECA11820

CAUTION:

- **DO NOT LOSE THE CODE RE-REGISTERING KEY! CONTACT YOUR DEALER IMMEDIATELY IF IT IS LOST!** If the code re-registering key is lost, registering new codes in the standard keys is impossible. The standard keys can still be used to start the vehicle, however if code re-registering is required (i.e., if a new standard key is made or all keys are lost) the entire immobilizer system must be replaced. Therefore, it is highly recom-

mended to use either standard key and keep the code re-registering key in a safe place.

- Do not submerge any key in water.
- Do not expose any key to excessively high temperatures.
- Do not place any key close to magnets (this includes, but not limited to, products such as speakers, etc.).
- Do not place heavy items on any key.
- Do not grind any key or alter its shape.
- Do not disassemble the plastic part of any key.
- Do not put two keys of any immobilizer system on the same key ring.
- Keep the standard keys as well as keys of other immobilizer systems away from this vehicle's code re-registering key.
- Keep other immobilizer system keys away from the main switch as they may cause signal interference.

INSTRUMENT AND CONTROL FUNCTIONS

Main switch/steering lock

EAU10471

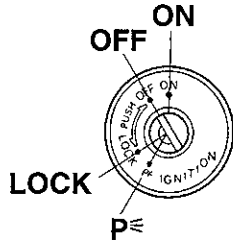

The main switch/steering lock controls the ignition and lighting systems, and is used to lock the steering.

NOTE: _____
Be sure to use the standard key (black bow) for regular use of the vehicle. To minimize the risk of losing the code re-registering key (red bow), keep it in a safe place and only use it for code re-registering.

ON

EAU33590

All electrical circuits are supplied with power; the meter lighting, taillight and auxiliary light come on, and the engine can be started. The key cannot be removed.

NOTE:

_____ The headlight comes on automatically when the engine is started and stays on until the key is turned to "OFF", even if the engine stalls.

OFF

EAU10660

All electrical systems are off. The key can be removed.

LOCK

EAU10690

The steering is locked, and all electrical systems are off. The key can be removed.

To lock the steering

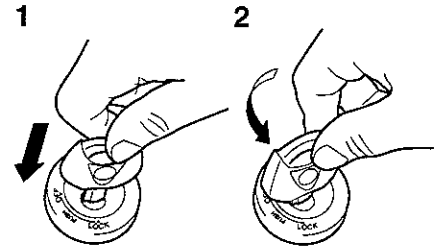

- 1 Push
- 2 Turn

- 1 Turn the handlebars all the way to the left or right.
- 2 Push the key in from the "OFF" position, and then turn it to "LOCK" while still pushing it.
- 3 Remove the key

INSTRUMENT AND CONTROL FUNCTIONS

To unlock the steering

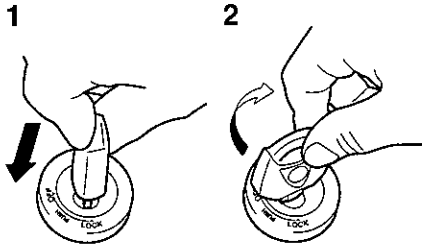

- 1 Push
- 2 Turn

Push the key into the main switch, and then turn it to "OFF" while still pushing it.

EWA10060

WARNING

Never turn the key to "OFF" or "LOCK" while the vehicle is moving, otherwise the electrical systems will be switched off, which may result in loss of control or an accident. Make sure that the vehicle is stopped before turning the key to "OFF" or "LOCK".

p<= (Parking)

EAU10920

The steering is locked, the taillight and auxiliary light are on, and the hazard light can be turned on, but all other electrical systems are off. The key can be removed.

The steering must be locked before the key can be turned to "p<="

ECA11020

CAUTION

Do not use the parking position for an extended length of time, otherwise the battery may discharge.

Indicator and warning lights

EAU11001

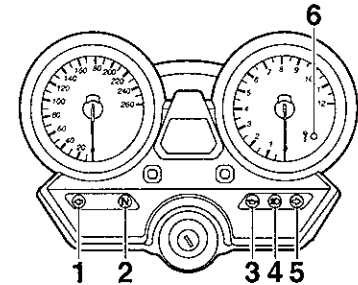

- 1 Left turn signal indicator light "↶"
- 2 Neutral indicator light "N"
- 3 Oil level warning light "⚠"
- 4 High beam indicator light "≡"
- 5 Right turn signal indicator light "↷"
- 6 Immobilizer system indicator light "⚡"

Turn signal indicator lights "↶" and "↷"

EAU11030

The corresponding indicator light flashes when the turn signal switch is pushed to the left or right.

Neutral indicator light "N"

EAU11060

This indicator light comes on when the transmission is in the neutral position.

INSTRUMENT AND CONTROL FUNCTIONS

High beam indicator light “” EAU11080

This indicator light comes on when the high beam of the headlight is switched on

Oil level warning light “” EAU11120

This warning light comes on when the engine oil level is low.

The electrical circuit of the warning light can be checked by turning the key to “ON”.

If the warning light does not come on for a few seconds, then go off, have a Yamaha dealer check the electrical circuit

NOTE: _____

Even if the oil level is sufficient, the warning light may flicker when riding on a slope or during sudden acceleration or deceleration, but this is not a malfunction

Immobilizer system indicator light “” EAU27020

The electrical circuit of the indicator light can be checked by turning the key to “ON”

If the indicator light does not come on for a few seconds, then go off, have a Yamaha dealer check the electrical circuit

When the key is turned to “OFF” and 30 seconds have passed, the indicator light will start flashing indicating the immobilizer system is enabled. After 24 hours have passed, the indicator light will stop flashing, however the immobilizer system is still enabled

NOTE: _____

This model is also equipped with a self-diagnosis device for the immobilizer system. If the immobilizer system is defective, the indicator light will start flashing a pattern when the key is turned to “ON”. When this occurs, have a Yamaha dealer check the self-diagnosis system. However, if the indicator light slowly flashes five times, and then quickly flashes two times repeatedly,

this error could be caused by signal interference. If this occurs, try the following.

- 1 Use the code re-registering key to start the engine

NOTE: _____

Make sure there are no other immobilizer keys close to the main switch, and do not keep more than one immobilizer key on the same key ring! Immobilizer system keys may cause signal interference, which may prevent the engine from starting

2. If the engine starts, turn it off, and try starting the engine with the standard keys
3. If one or both of the standard keys do not start the engine, take the vehicle, the code re-registering key and both standard keys to a Yamaha dealer and have the standard keys re-registered.

INSTRUMENT AND CONTROL FUNCTIONS

Speedometer

EAU11601

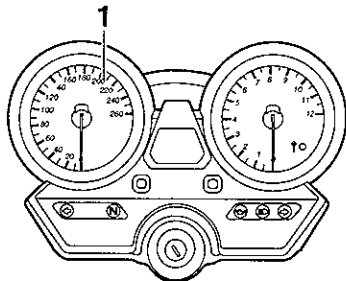

1 Speedometer

The speedometer shows the riding speed

When the key is turned to "ON", the speedometer needle will sweep once across the speed range and then return to zero in order to test the electrical circuit

Tachometer

EAU11872

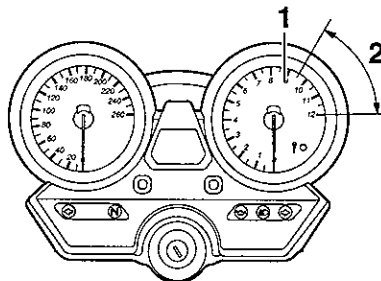

1 Tachometer
2 Tachometer red zone

The electric tachometer allows the rider to monitor the engine speed and keep it within the ideal power range.

When the key is turned to "ON", the tachometer needle will sweep once across the r/min range and then return to zero r/min in order to test the electrical circuit.

CAUTION:

Do not operate the engine in the tachometer red zone.

Red zone: 9500 r/min and above

ECA10031

Self-diagnosis device

EAU11991

This model is equipped with a self-diagnosis device for the following electrical circuits:

- throttle position sensor
- speed sensor

If any of those circuits are defective, the tachometer will repeatedly display the following error code:

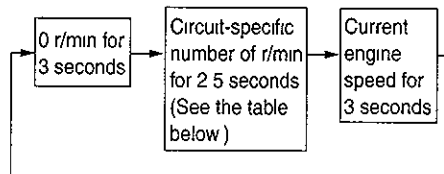

Use the table below to identify the faulty electrical circuit.

Specific r/min for the faulty circuit

Throttle position sensor.
3000 r/min
Speed sensor
4000 r/min

If the tachometer displays such an error code, note the circuit-specific number of r/min, and then have a Yamaha dealer check the vehicle.

INSTRUMENT AND CONTROL FUNCTIONS

ECA10040

CAUTION:

When the tachometer displays an error code, the vehicle should be checked as soon as possible in order to avoid engine damage.

EAU33572

Multi-function display

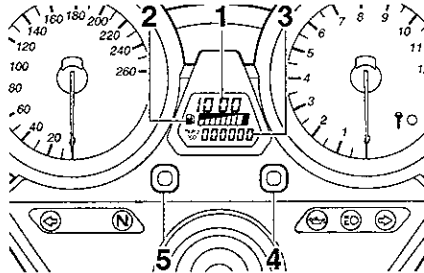

- 1 Clock
- 2 Fuel meter
- 3 Odometer/tripmeters
- 4 "RESET" button
- 5 "SELECT" button

The multi-function display is equipped with the following:

- an odometer (which shows the total distance traveled)
- two tripmeters (which show the distance traveled since they were last set to zero)
- a fuel meter
- a clock

NOTE:

Be sure to turn the key to "ON" before using the "SELECT" and "RESET" buttons

Odometer and tripmeter modes

Pushing the "SELECT" button switches the display between the odometer mode "ODO" and the tripmeter modes "TRIP 1" and "TRIP 2" in the following order:

ODO → TRIP 1 → TRIP 2 → ODO

To reset a tripmeter, select it by pushing the "SELECT" button, and then push the "RESET" button for at least one second. The tripmeters can be used to estimate the distance that can be traveled with a full tank of fuel. This information will enable you to plan future fuel stops.

Fuel meter

The fuel meter indicates the amount of fuel in the fuel tank. The display segments of the fuel meter disappear towards "E" (Empty) as the fuel level decreases. When only one segment is left near "E", refuel as soon as possible.

INSTRUMENT AND CONTROL FUNCTIONS

NOTE:

This fuel meter is equipped with a self-diagnosis system. If the electrical circuit is defective, the display segments and symbol "E" will flash. If this occurs, have a Yamaha dealer check the electrical circuit

3

Clock mode

To set the clock:

- 1 Turn the key to "ON".
- 2 Push the "SELECT" button and "RESET" button together for at least two seconds
3. When the hour digits start flashing, push the "RESET" button to set the hours.
4. Push the "SELECT" button, and the minute digits will start flashing.
- 5 Push the "RESET" button to set the minutes
- 6 Push the "SELECT" button and then release it to start the clock

Handlebar switches

Left

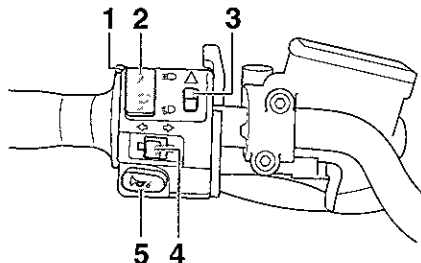

- 1 Pass switch "PASS"
- 2 Dimmer switch "☰/☷"
- 3 Hazard switch "▲"
- 4 Turn signal switch "↔"
- 5 Horn switch "📢"

EAU12342

Right

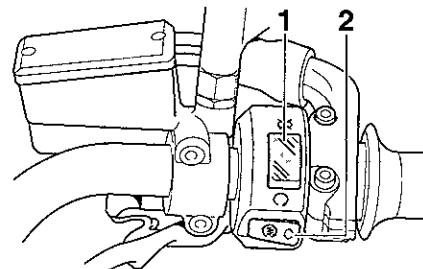

- 1 Engine stop switch "⊙/⊗"
- 2 Start switch "🔑"

Pass switch "PASS"

Press this switch to flash the headlight

EAU12360

Dimmer switch "☰/☷"

Set this switch to "☰" for the high beam and to "☷" for the low beam.

EAU12400

Turn signal switch "↔"

To signal a right-hand turn, push this switch to "↗". To signal a left-hand turn, push this switch to "↖". When released, the switch returns to the center

EAU12460

INSTRUMENT AND CONTROL FUNCTIONS

position To cancel the turn signal lights, push the switch in after it has returned to the center position



EAU12500

Horn switch “”

Press this switch to sound the horn

Engine stop switch “”

EAU12660

Set this switch to “” before starting the engine. Set this switch to “” to stop the engine in case of an emergency, such as when the vehicle overturns or when the throttle cable is stuck.

EAU12710

Start switch “”

Push this switch to crank the engine with the starter.

ECA10050

CAUTION:

See page 5-1 for starting instructions prior to starting the engine.

EAU12731

Hazard switch “”

With the key in the “ON” or “P” position, use this switch to turn on the hazard light (simultaneous flashing of all turn signal lights).

The hazard light is used in case of an emergency or to warn other drivers when your vehicle is stopped where it might be a traffic hazard

ECA10060

CAUTION:

Do not use the hazard light for an extended length of time, otherwise the battery may discharge.

EAU12830

Clutch lever

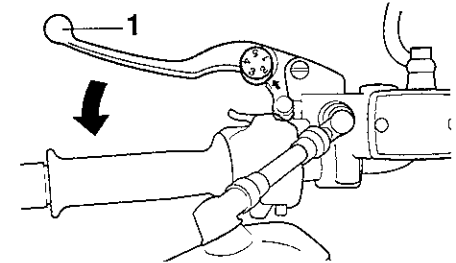

1 Clutch lever

The clutch lever is located at the left handlebar grip. To disengage the clutch, pull the lever toward the handlebar grip. To engage the clutch, release the lever. The lever should be pulled rapidly and released slowly for smooth clutch operation

INSTRUMENT AND CONTROL FUNCTIONS

3

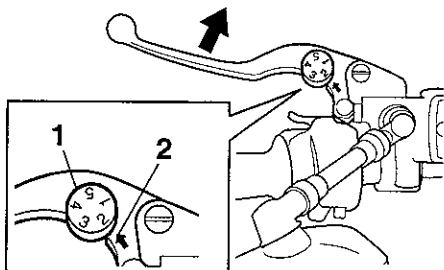

- 1 Clutch lever position adjusting dial
- 2 Arrow mark

The clutch lever is equipped with a clutch lever position adjusting dial. To adjust the distance between the clutch lever and the handlebar grip, turn the adjusting dial while holding the lever pushed away from the handlebar grip. Make sure that the appropriate setting on the adjusting dial is aligned with the arrow mark on the clutch lever.

The clutch lever is equipped with a clutch switch, which is part of the ignition circuit cut-off system (See page 3-18)

Shift pedal

EAU12870

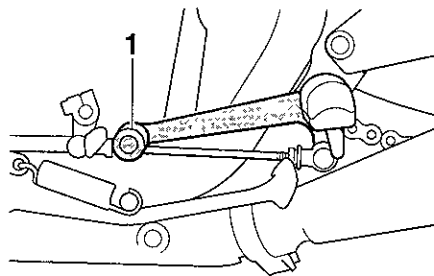

- 1 Shift pedal

The shift pedal is located on the left side of the engine and is used in combination with the clutch lever when shifting the gears of the 5-speed constant-mesh transmission equipped on this motorcycle.

Brake lever

EAU26822

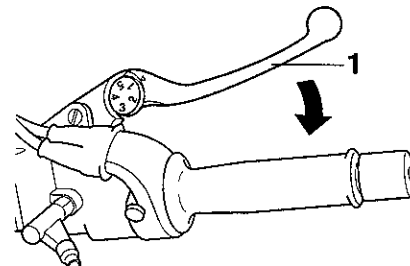

- 1 Brake lever

The brake lever is located at the right handlebar grip. To apply the front brake, pull the lever toward the handlebar grip.

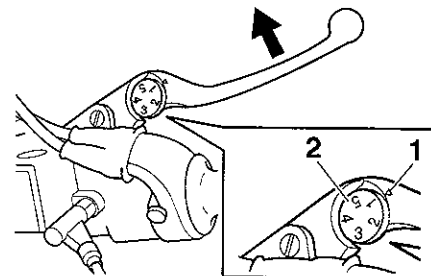

- 1 "△" mark
- 2 Brake lever position adjusting dial

INSTRUMENT AND CONTROL FUNCTIONS

The brake lever is equipped with a position adjusting dial. To adjust the distance between the brake lever and the handlebar grip, turn the adjusting dial while holding the lever pushed away from the handlebar grip. Make sure that the appropriate setting on the adjusting dial is aligned with the “△” mark on the brake lever.

Brake pedal

EAU12941

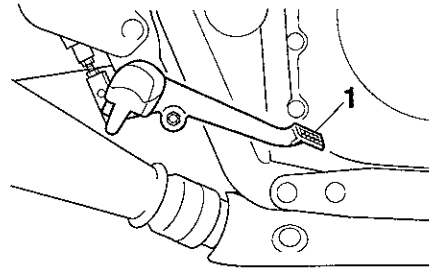

- 1 Brake pedal

The brake pedal is on the right side of the motorcycle. To apply the rear brake, press down on the brake pedal.

Fuel tank cap

EAU13070

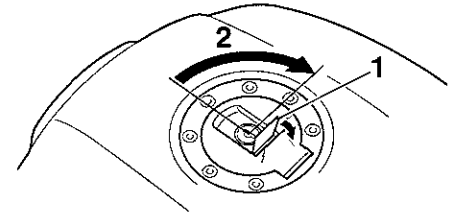

- 1 Fuel tank cap lock cover
- 2 Unlock

To open the fuel tank cap

Open the fuel tank cap lock cover, insert the key into the lock, and then turn it 1/4 turn clockwise. The lock will be released and the fuel tank cap can be opened.

To close the fuel tank cap

- 1 Push the fuel tank cap into position with the key inserted in the lock.
2. Turn the key counterclockwise to the original position, remove it, and then close the lock cover.

INSTRUMENT AND CONTROL FUNCTIONS

NOTE:

The fuel tank cap cannot be closed unless the key is in the lock. In addition, the key cannot be removed if the cap is not properly closed and locked

EWA11090

WARNING

Make sure that the fuel tank cap is properly closed before riding.

3

Fuel

EAU13210

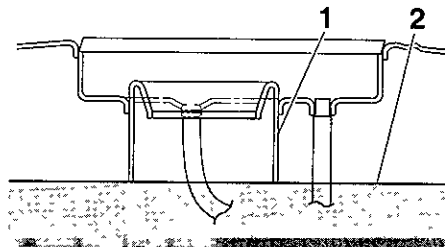

- 1 Fuel tank filler tube
- 2 Fuel level

Make sure that there is sufficient fuel in the tank. Fill the fuel tank to the bottom of the filler tube as shown

EWA10880

WARNING

- Do not overfill the fuel tank, otherwise it may overflow when the fuel warms up and expands.
- Avoid spilling fuel on the hot engine.

CAUTION:

Immediately wipe off spilled fuel with a clean, dry, soft cloth, since fuel may deteriorate painted surfaces or plastic parts.

ECA10070

EAU13330

Recommended fuel:
UNLEADED GASOLINE ONLY
Fuel tank capacity:
21.0 L (5.55 US gal) (4.62 Imp gal)
Fuel reserve amount:
4.5 L (1.19 US gal) (0.99 Imp gal)

ECA11400

CAUTION:

Use only unleaded gasoline. The use of leaded gasoline will cause severe damage to internal engine parts, such as the valves and piston rings, as well as to the exhaust system.

Your Yamaha engine has been designed to use regular unleaded gasoline with a research octane number of 91 or higher. If knocking (or pinging) occurs, use a gasoline of a different brand

INSTRUMENT AND CONTROL FUNCTIONS

or premium unleaded fuel. Use of unleaded fuel will extend spark plug life and reduce maintenance costs.

EAU13440

Catalytic converter

This vehicle is equipped with a catalytic converter in the muffler.

EWA10860

WARNING

The exhaust system is hot after operation. Make sure that the exhaust system has cooled down before doing any maintenance work.

ECA10700

CAUTION:

The following precautions must be observed to prevent a fire hazard or other damages.

- Use only unleaded gasoline. The use of leaded gasoline will cause unreparable damage to the catalytic converter.
- Never park the vehicle near possible fire hazards such as grass or other materials that easily burn.
- Do not allow the engine to idle too long.

EAU13570

Fuel cock

The fuel cock supplies fuel from the tank to the carburetors while also filtering it.

The fuel cock lever positions are explained as follows and shown in the illustrations.

ON

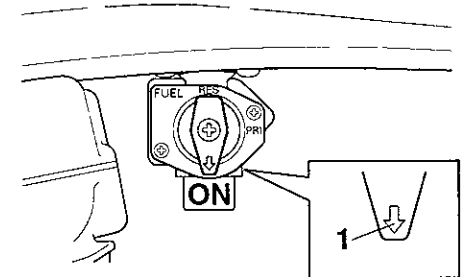

1 Arrow mark positioned over "ON"

With the fuel cock lever in this position, fuel flows to the carburetors when the engine is running. Turn the fuel cock lever to this position when starting the engine and riding.

INSTRUMENT AND CONTROL FUNCTIONS

RES

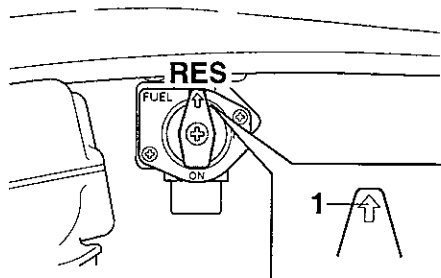

1 Arrow mark positioned over "RES"

This indicates reserve. With the fuel cock lever in this position, the fuel reserve is made available. Quickly turn the fuel cock lever to this position if you run out of fuel while riding, otherwise the engine may stall and will have to be primed (see "PRI") After turning the fuel cock lever to "RES", refuel as soon as possible and be sure to turn the fuel cock lever back to "ON"

PRI

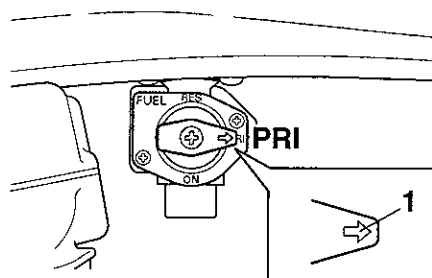

1 Arrow mark positioned over "PRI"

This indicates prime. With the fuel cock lever in this position, the engine can be "primed". Turn the fuel cock lever to this position when the engine has been allowed to run out of fuel. This sends fuel directly to the carburetors, which will make starting easier. After the engine has started, be sure to turn the lever to "ON" (or "RES" if you have not refueled yet)

Starter (choke) lever "N"

EAU13590

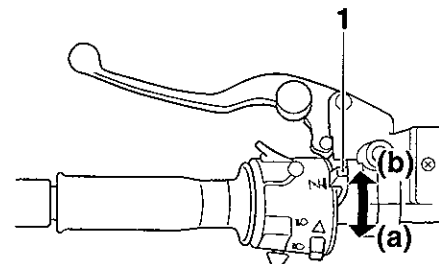

1 Starter (choke) lever "N"

Starting a cold engine requires a richer air-fuel mixture, which is supplied by the starter (choke). Move the lever in direction (a) to turn on the starter (choke). Move the lever in direction (b) to turn off the starter (choke).

INSTRUMENT AND CONTROL FUNCTIONS

Seat

EAU13900

To remove the seat

- 1 Insert the key into the seat lock, and then turn it as shown.

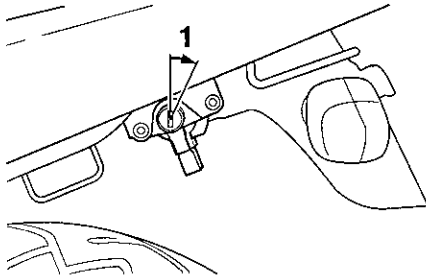

1 Unlock

2. Pull the seat off.

To install the seat

- 1 Insert the projection on the front of the seat into the seat holder as shown

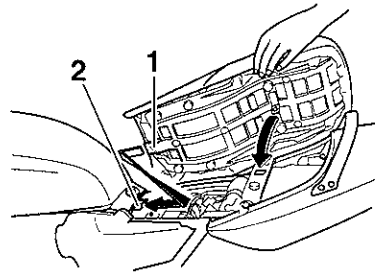

- 1 Projection
- 2 Seat holder

- 2 Push the rear of the seat down to lock it in place
- 3 Remove the key.

NOTE:

Make sure that the seat is properly secured before riding.

Helmet holder

EAU14350

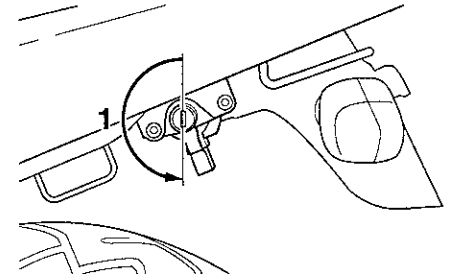

1 Unlock

To open the helmet holder, insert the key into the seat lock, and then turn the key as shown

To lock the helmet holder, turn the key to the original position, and then remove it

EWA10160

WARNING

Never ride with a helmet attached to the helmet holder, since the helmet may hit objects, causing loss of control and possibly an accident.

INSTRUMENT AND CONTROL FUNCTIONS

Storage compartment

EAU14451

When washing the vehicle, be careful not to let any water enter the storage compartment.

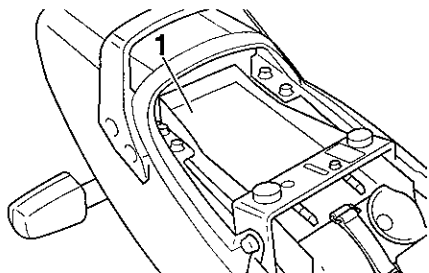

1 Storage compartment

The storage compartment is located under the seat. (See page 3-14.)

EWA10961

WARNING

- Do not exceed the load limit of 3 kg (7 lb) for the storage compartment.
- Do not exceed the maximum load of 203 kg (448 lb) for the vehicle.

When storing the owner's manual or other documents in the storage compartment, be sure to wrap them in a plastic bag so that they will not get wet

Adjusting the front fork

EAU14720

This front fork is equipped with spring preload adjusting bolts.

EWA10180

WARNING

Always adjust both fork legs equally, otherwise poor handling and loss of stability may result.

Adjust the spring preload as follows

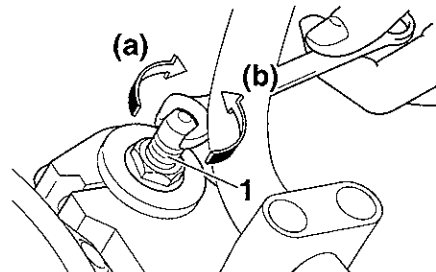

1 Spring preload adjusting bolt

To increase the spring preload and thereby harden the suspension, turn the adjusting bolt on each fork leg in direction (a). To decrease the spring preload and thereby soften the suspension, turn the adjusting bolt on each fork leg in direction (b)

INSTRUMENT AND CONTROL FUNCTIONS

NOTE: _____
Align the appropriate groove on the adjusting mechanism with the top of the front fork cap bolt

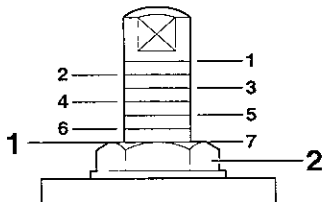

- 1 Current setting
- 2 Front fork cap bolt

Spring preload setting:

- Minimum (soft)
7
- Standard
5
- Maximum (hard)
1

Adjusting the shock absorber assemblies

EAU14900

Each shock absorber assembly is equipped with a spring preload adjusting ring.

ECA10100

CAUTION:

Never attempt to turn an adjusting mechanism beyond the maximum or minimum settings.

EWA10210

WARNING

Always adjust both shock absorber assemblies equally, otherwise poor handling and loss of stability may result.

Adjust the spring preload as follows, using the special wrenches included along with the owner's tool kit.

To increase the spring preload and thereby harden the suspension, hold the upper ring in place while turning the lower ring (adjusting ring) on each shock absorber assembly as shown in direction (a)

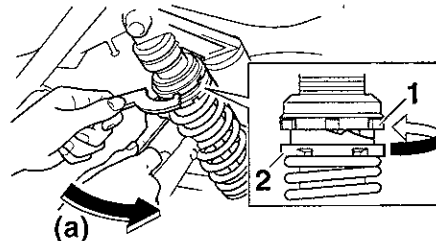

- 1 Upper ring
- 2 Lower ring (spring preload adjusting ring)

To decrease the spring preload and thereby soften the suspension, hold the upper ring in place while turning the lower ring (adjusting ring) on each shock absorber assembly as shown in direction (b).

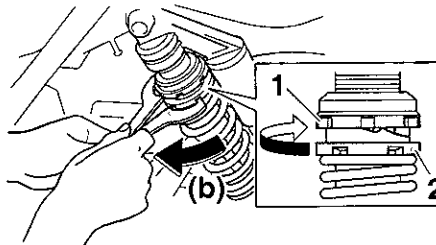

- 1 Upper ring
- 2 Lower ring (spring preload adjusting ring)

INSTRUMENT AND CONTROL FUNCTIONS

Setting:

Minimu (soft) / standard

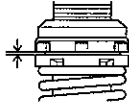

Medium

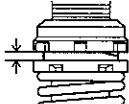

Maximum (hard)

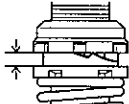

EWA10230

WARNING

These shock absorbers contain highly pressurized nitrogen gas. For proper handling read and understand the following information before handling the shock absorbers. The manufacturer cannot be held responsible for property damage or personal injury that may result from improper handling.

- Do not tamper with or attempt to open the gas cylinders.
- Do not subject the shock absorbers to an open flame or other high heat sources, otherwise they may explode due to excessive gas pressure.
- Do not deform or damage the gas cylinders in any way, as this will result in poor damping performance.
- Always have a Yamaha dealer service the shock absorbers.

Luggage strap holders

EAU15230

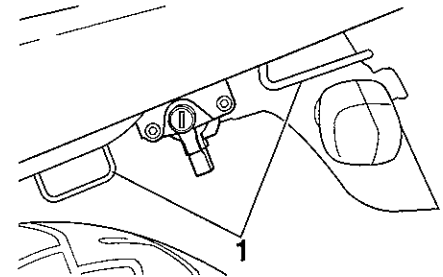

1 Luggage strap holder

There are four luggage strap holders, two of which can be turned out for easier access

INSTRUMENT AND CONTROL FUNCTIONS

Sidestand

EAU15300

The sidestand is located on the left side of the frame. Raise the sidestand or lower it with your foot while holding the vehicle upright.

NOTE:

The built-in sidestand switch is part of the ignition circuit cut-off system, which cuts the ignition in certain situations. (See further down for an explanation of the ignition circuit cut-off system.)

EWA10240

WARNING

The vehicle must not be ridden with the sidestand down, or if the sidestand cannot be properly moved up (or does not stay up), otherwise the sidestand could contact the ground and distract the operator, resulting in a possible loss of control. Yamaha's ignition circuit cut-off system has been designed to assist the operator in fulfilling the responsibility of raising the sidestand before starting off. Therefore, check this system regularly as described

below and have a Yamaha dealer repair it if it does not function properly.

EAU15321

Ignition circuit cut-off system

The ignition circuit cut-off system (comprising the sidestand switch, clutch switch and neutral switch) has the following functions.

- It prevents starting when the transmission is in gear and the sidestand is up, but the clutch lever is not pulled.
- It prevents starting when the transmission is in gear and the clutch lever is pulled, but the sidestand is still down.
- It cuts the running engine when the transmission is in gear and the sidestand is moved down.

Periodically check the operation of the ignition circuit cut-off system according to the following procedure.

EWA10260

WARNING

- The vehicle must be placed on the centerstand during this inspection.
- If a malfunction is noted, have a Yamaha dealer check the system before riding.

INSTRUMENT AND CONTROL FUNCTIONS

3

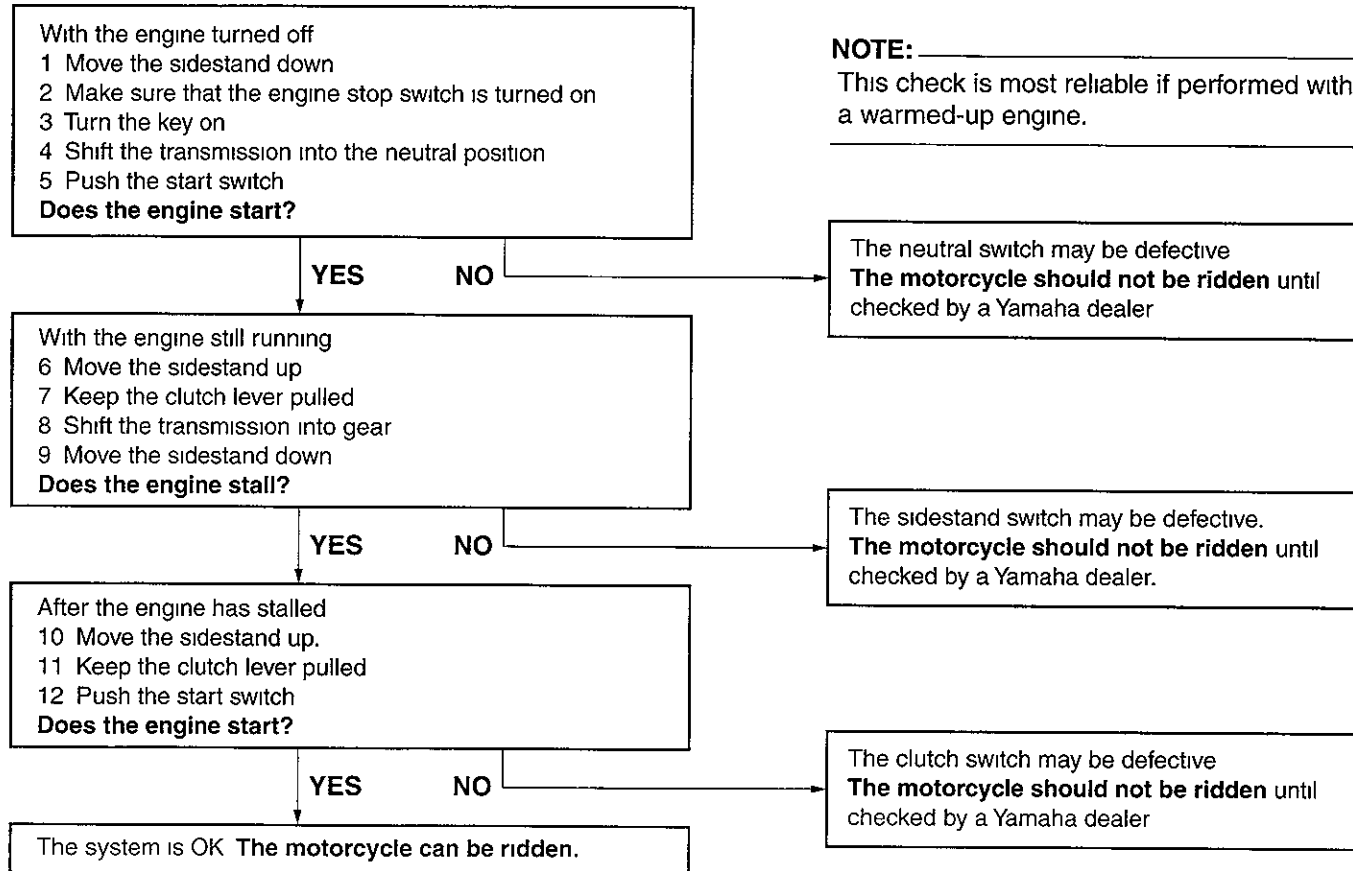

PRE-OPERATION CHECKS

EAU15591

The condition of a vehicle is the owner's responsibility. Vital components can start to deteriorate quickly and unexpectedly, even if the vehicle remains unused (for example, as a result of exposure to the elements) Any damage, fluid leakage or loss of tire air pressure could have serious consequences. Therefore, it is very important, in addition to a thorough visual inspection, to check the following points before each ride.

NOTE:

Pre-operation checks should be made each time the vehicle is used. Such an inspection can be accomplished in a very short time, and the added safety it assures is more than worth the time involved

EWA11150

 **WARNING**

If any item in the Pre-operation check list is not working properly, have it inspected and repaired before operating the vehicle.

PRE-OPERATION CHECKS

EAU15602

Pre-operation check list

ITEM	CHECKS	PAGE
Fuel	<ul style="list-style-type: none">• Check fuel level in fuel tank• Refuel if necessary• Check fuel line for leakage	3-11
Engine oil	<ul style="list-style-type: none">• Check oil level in engine• If necessary, add recommended oil to specified level• Check vehicle for oil leakage	6-8
Front brake	<ul style="list-style-type: none">• Check operation• If soft or spongy, have Yamaha dealer bleed hydraulic system• Check brake pads for wear• Replace if necessary• Check fluid level in reservoir• If necessary, add recommended brake fluid to specified level• Check hydraulic system for leakage	6-17, 6-18
Rear brake	<ul style="list-style-type: none">• Check operation• If soft or spongy, have Yamaha dealer bleed hydraulic system• Check brake pads for wear• Replace if necessary• Check fluid level in reservoir• If necessary, add recommended brake fluid to specified level• Check hydraulic system for leakage	6-16, 6-17, 6-18
Clutch	<ul style="list-style-type: none">• Check operation• If soft or spongy, have Yamaha dealer bleed hydraulic system• Check fluid level in reservoir• If necessary, add recommended fluid to specified level• Check hydraulic system for leakage	6-16, 6-18
Throttle grip	<ul style="list-style-type: none">• Make sure that operation is smooth• Check cable free play• If necessary, have Yamaha dealer adjust cable free play and lubricate cable and grip housing	6-12, 6-22

PRE-OPERATION CHECKS

ITEM	CHECKS	PAGE
Control cables	<ul style="list-style-type: none"> • Make sure that operation is smooth • Lubricate if necessary 	6-22
Drive chain	<ul style="list-style-type: none"> • Check chain slack • Adjust if necessary • Check chain condition • Lubricate if necessary 	6-20, 6-21
Wheels and tires	<ul style="list-style-type: none"> • Check for damage • Check tire condition and tread depth • Check air pressure • Correct if necessary 	6-13, 6-15
Brake and shift pedals	<ul style="list-style-type: none"> • Make sure that operation is smooth • Lubricate pedal pivoting points if necessary 	6-22
Brake and clutch levers	<ul style="list-style-type: none"> • Make sure that operation is smooth • Lubricate lever pivoting points if necessary 	6-23
Centerstand, sidestand	<ul style="list-style-type: none"> • Make sure that operation is smooth • Lubricate pivots if necessary 	6-24
Chassis fasteners	<ul style="list-style-type: none"> • Make sure that all nuts, bolts and screws are properly tightened • Tighten if necessary 	—
Instruments, lights, signals and switches	<ul style="list-style-type: none"> • Check operation • Correct if necessary 	—
Sidestand switch	<ul style="list-style-type: none"> • Check operation of ignition circuit cut-off system • If system is defective, have Yamaha dealer check vehicle 	3-18

OPERATION AND IMPORTANT RIDING POINTS

EAU15950

EAU16300

EWA10270

WARNING

- Become thoroughly familiar with all operating controls and their functions before riding. Consult a Yamaha dealer regarding any control or function that you do not thoroughly understand.
- Never start the engine or operate it in a closed area for any length of time. Exhaust fumes are poisonous, and inhaling them can cause loss of consciousness and death within a short time. Always make sure that there is adequate ventilation.
- Before starting out, make sure that the sidestand is up. If the sidestand is not raised completely, it could contact the ground and distract the operator, resulting in a possible loss of control.

Starting and warming up a cold engine

In order for the ignition circuit cut-off system to enable starting, one of the following conditions must be met.

- The transmission is in the neutral position.
- The transmission is in gear with the clutch lever pulled and the sidestand up

EWA10290

WARNING

- Before starting the engine, check the function of the ignition circuit cut-off system according to the procedure described on page 3-18.
- Never ride with the sidestand down.

- 1 Turn the fuel cock lever to "ON".
- 2 Turn the key to "ON" and make sure that the engine stop switch is set to "O"
- 3 Shift the transmission into the neutral position

NOTE:

When the transmission is in the neutral position, the neutral indicator light should be on, otherwise have a Yamaha dealer check the electrical circuit

4. Turn the starter (choke) on and completely close the throttle. (See page 3-13)
- 5 Start the engine by pushing the start switch

NOTE:

If the engine fails to start, release the start switch, wait a few seconds, and then try again. Each starting attempt should be as short as possible to preserve the battery. Do not crank the engine more than 10 seconds on any one attempt.

ECA10860

CAUTION:

The oil level warning light should come on when the key is turned to "ON", and then go off after two to three seconds. If the oil level warning light flickers or remains on after starting, immediately stop the en-

OPERATION AND IMPORTANT RIDING POINTS

gine, and then check the engine oil level and the vehicle for oil leakage. If necessary, add engine oil, and then check the warning light again. If the warning light does not come on when turning the key to "ON", or if it does not go off after starting the engine with sufficient engine oil, have a Yamaha dealer check the electrical circuit.

- 6 After starting the engine, move the starter (choke) back halfway

ECA11130

CAUTION

For maximum engine life, always warm the engine up before starting off. Never accelerate hard when the engine is cold!

- 7 When the engine is warm, turn the starter (choke) off

NOTE:

The engine is warm when it responds normally to the throttle with the starter (choke) turned off.

EAU16640

Starting a warm engine

Follow the same procedure as for starting a cold engine with the exception that the starter (choke) is not required when the engine is warm

EAU16671

Shifting

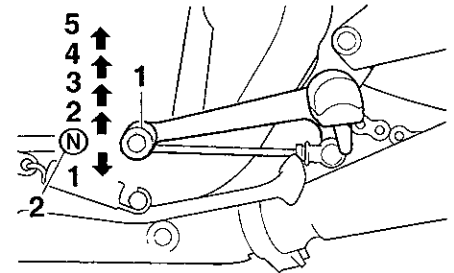

- 1 Shift pedal
- 2 Neutral position

Shifting gears lets you control the amount of engine power available for starting off, accelerating, climbing hills, etc.

The gear positions are shown in the illustration

NOTE:

To shift the transmission into the neutral position, press the shift pedal down repeatedly until it reaches the end of its travel, and then slightly raise it

OPERATION AND IMPORTANT RIDING POINTS

5

CAUTION

- Even with the transmission in the neutral position, do not coast for long periods of time with the engine off, and do not tow the motorcycle for long distances. The transmission is properly lubricated only when the engine is running. Inadequate lubrication may damage the transmission.
- Always use the clutch while changing gears to avoid damaging the engine, transmission, and drive train, which are not designed to withstand the shock of forced shifting.

ECA10260

Tips for reducing fuel consumption

Fuel consumption depends largely on your riding style. Consider the following tips to reduce fuel consumption:

- Turn the starter (choke) off as soon as possible.
- Shift up swiftly, and avoid high engine speeds during acceleration
- Do not rev the engine while shifting down, and avoid high engine speeds with no load on the engine.
- Turn the engine off instead of letting it idle for an extended length of time (e.g., in traffic jams, at traffic lights or at railroad crossings)

EAU16800

Engine break-in

There is never a more important period in the life of your engine than the period between 0 and 1600 km (1000 mi). For this reason, you should read the following material carefully.

Since the engine is brand new, do not put an excessive load on it for the first 1600 km (1000 mi). The various parts in the engine wear and polish themselves to the correct operating clearances. During this period, prolonged full-throttle operation or any condition that might result in engine overheating must be avoided.

EAU16841

EAU17091

0–1000 km (0–600 mi)

Avoid prolonged operation above 4000 r/min.

1000–1600 km (600–1000 mi)

Avoid prolonged operation above 5000 r/min.

OPERATION AND IMPORTANT RIDING POINTS

ECA10301

CAUTION:

After 1000 km (600 mi) of operation, the engine oil must be changed and the oil filter cartridge or element replaced.

1600 km (1000 mi) and beyond

The vehicle can now be operated normally.

ECA10310

CAUTION:

- Keep the engine speed out of the tachometer red zone.
- If any engine trouble should occur during the engine break-in period, immediately have a Yamaha dealer check the vehicle.

EAU17211

Parking

When parking, stop the engine, and then remove the key from the main switch.

EWA10310

⚠ WARNING

- Since the engine and exhaust system can become very hot, park in a place where pedestrians or children are not likely to touch them.
- Do not park on a slope or on soft ground, otherwise the vehicle may overturn.

ECA10380

CAUTION:

Never park in an area where there are fire hazards such as grass or other flammable materials.

PERIODIC MAINTENANCE AND MINOR REPAIR

EAU17240

Safety is an obligation of the owner. Periodic inspection, adjustment and lubrication will keep your vehicle in the safest and most efficient condition possible. The most important points of inspection, adjustment, and lubrication are explained on the following pages. The intervals given in the periodic maintenance and lubrication chart should be simply considered as a general guide under normal riding conditions. However, **DEPENDING ON THE WEATHER, TERRAIN, GEOGRAPHICAL LOCATION, AND INDIVIDUAL USE, THE MAINTENANCE INTERVALS MAY NEED TO BE SHORTENED.**

EWA10320

⚠ WARNING

If you are not familiar with maintenance work, have a Yamaha dealer do it for you.

Owner's tool kit

EAU17380

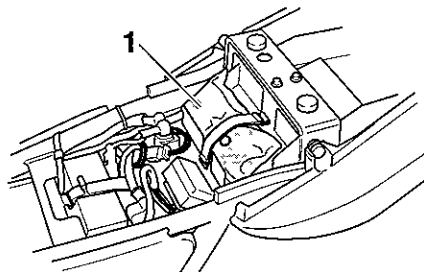

1 Owner's tool kit

The owner's tool kit is located under the seat (See page 3-14)

The service information included in this manual and the tools provided in the owner's tool kit are intended to assist you in the performance of preventive maintenance and minor repairs. However, additional tools such as a torque wrench may be necessary to perform certain maintenance work correctly.

NOTE:

If you do not have the tools or experience required for a particular job, have a Yamaha dealer perform it for you

⚠ WARNING

Modifications not approved by Yamaha may cause loss of performance and render the vehicle unsafe for use. Consult a Yamaha dealer before attempting any changes.

EWA10350

PERIODIC MAINTENANCE AND MINOR REPAIR

EAU17702

Periodic maintenance and lubrication chart

NOTE:

- The annual checks must be performed every year, except if a kilometer-based maintenance is performed instead.
- From 50000 km, repeat the maintenance intervals starting from 10000 km.
- Items marked with an asterisk should be performed by a Yamaha dealer as they require special tools, data and technical skills.

NO.	ITEM	CHECK OR MAINTENANCE JOB	ODOMETER READING (× 1000 km)					ANNUAL CHECK
			1	10	20	30	40	
1	* Fuel line	• Check fuel and vacuum hoses for cracks or damage		√	√	√	√	√
2	* Fuel filter	• Check condition			√		√	
3	Spark plugs	• Check condition • Clean and regap		√		√		
		• Replace			√		√	
4	* Valves	• Check valve clearance • Adjust	Every 20000 km					
5	Air filter element	• Clean		√		√		
		• Replace			√		√	
6	* Clutch	• Check operation, fluid level and vehicle for fluid leakage	√	√	√	√	√	
7	* Front brake	• Check operation, fluid level and vehicle for fluid leakage	√	√	√	√	√	√
		• Replace brake pads	Whenever worn to the limit					
8	* Rear brake	• Check operation, fluid level and vehicle for fluid leakage	√	√	√	√	√	√
		• Replace brake pads	Whenever worn to the limit					

PERIODIC MAINTENANCE AND MINOR REPAIR

NO.	ITEM	CHECK OR MAINTENANCE JOB	ODOMETER READING (× 1000 km)					ANNUAL CHECK
			1	10	20	30	40	
9	* Brake hoses	• Check for cracks or damage		√	√	√	√	√
		• Replace	Every 4 years					
10	* Wheels	• Check runout and for damage		√	√	√	√	
11	* Tires	• Check tread depth and for damage • Replace if necessary • Check air pressure • Correct if necessary		√	√	√	√	√
12	* Wheel bearings	• Check bearing for looseness or damage		√	√	√	√	
13	* Swingarm	• Check operation and for excessive play		√	√	√	√	
		• Lubricate with lithium-soap-based grease	Every 50000 km					
14	Drive chain	• Check chain slack • Make sure that the rear wheel is properly aligned • Clean and lubricate	Every 1000 km and after washing the motorcycle or riding in the rain					
15	* Steering bearings	• Check bearing play and steering for roughness	√	√	√	√	√	
		• Lubricate with lithium-soap-based grease	Every 20000 km					
16	* Chassis fasteners	• Make sure that all nuts, bolts and screws are properly tightened		√	√	√	√	√
17	Sidestand, centerstand	• Check operation • Lubricate		√	√	√	√	√
18	* Sidestand switch	• Check operation	√	√	√	√	√	√
19	* Front fork	• Check operation and for oil leakage		√	√	√	√	
20	* Shock absorber assemblies	• Check operation and shock absorbers for oil leakage		√	√	√	√	
21	* Carburetors	• Check starter (choke) operation • Adjust engine idling speed and synchronization	√	√	√	√	√	√

PERIODIC MAINTENANCE AND MINOR REPAIR

NO.	ITEM	CHECK OR MAINTENANCE JOB	ODOMETER READING (× 1000 km)					ANNUAL CHECK
			1	10	20	30	40	
22	Engine oil	<ul style="list-style-type: none"> • Change • Check oil level and vehicle for oil leakage 	√	√	√	√	√	√
23	Engine oil filter element	<ul style="list-style-type: none"> • Replace 	√		√		√	
24	* Front and rear brake switches	<ul style="list-style-type: none"> • Check operation 	√	√	√	√	√	√
25	Moving parts and cables	<ul style="list-style-type: none"> • Lubricate 		√	√	√	√	√
26	* Throttle grip housing and cable	<ul style="list-style-type: none"> • Check operation and free play • Adjust the throttle cable free play if necessary • Lubricate the throttle grip housing and cable 		√	√	√	√	√
27	* Muffler and exhaust pipe	<ul style="list-style-type: none"> • Check the screw clamp for looseness 	√	√	√	√	√	
28	* Lights, signals and switches	<ul style="list-style-type: none"> • Check operation • Adjust headlight beam 	√	√	√	√	√	√

NOTE:

- The air filter needs more frequent service if you are riding in unusually wet or dusty areas.
- Hydraulic brake and clutch service
 - Regularly check and, if necessary, correct the brake and clutch fluid levels
 - Every two years replace the internal components of the brake master cylinders and calipers as well as clutch master and release cylinders, and change the brake and clutch fluids.
 - Replace the brake and clutch hoses every four years and if cracked or damaged.

PERIODIC MAINTENANCE AND MINOR REPAIR

EAU18771

Removing and installing panels

The panels shown need to be removed to perform some of the maintenance jobs described in this chapter. Refer to this section each time a panel needs to be removed and installed.

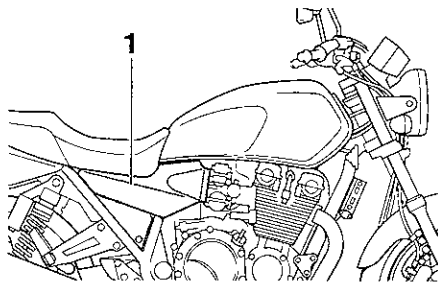

1 Panel A

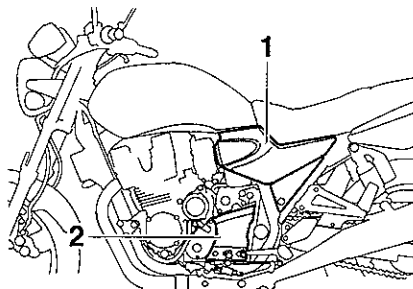

- 1 Panel B
- 2 Panel C

Panel A

EAU33550

To remove the panel

- 1 Remove the seat. (See page 3-14.)
- 2 Remove the bolt, and then pull the panel off as shown.

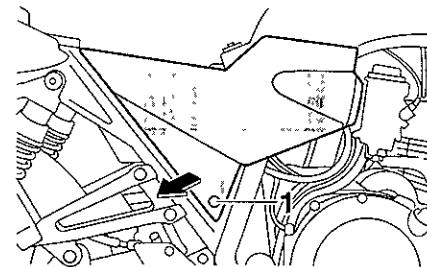

1 Bolt

To install the panel

- 1 Place the panel in the original position, and then install the bolt.

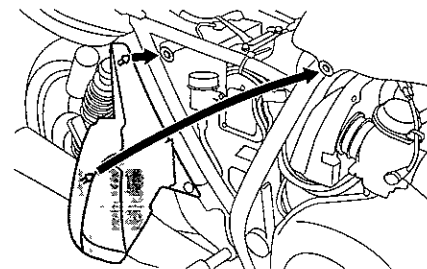

2. Install the seat.

PERIODIC MAINTENANCE AND MINOR REPAIR

ECA12830

CAUTION:

The area shown is not a storage compartment. Placing items here could block the air intake resulting in poor engine performance or engine damage.

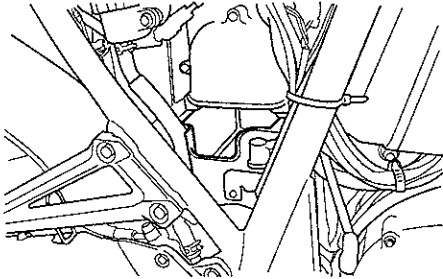

EAU33020

Panel B

To remove the panel

- 1 Remove the seat (See page 3-14)
- 2 Remove the bolt, and then pull the panel off as shown.

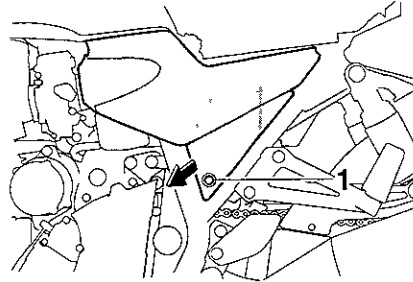

1 Bolt

To install the panel

- 1 Place the panel in the original position, and then install the bolt.

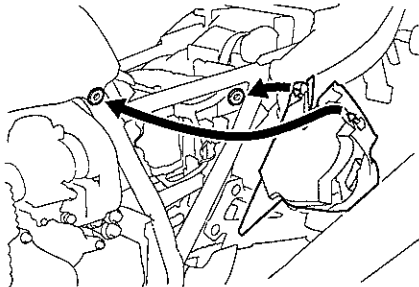

2. Install the seat.

EAU19192

Panel C

To remove the panel

Remove the bolts, and then take the panel off.

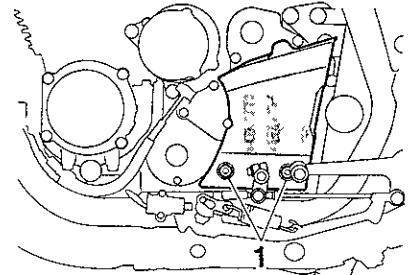

1 Bolt

To install the panel

Place the panel in the original position, and then install the bolts.

PERIODIC MAINTENANCE AND MINOR REPAIR

EAU19543

Checking the spark plugs

The spark plugs are important engine components, which are easy to check. Since heat and deposits will cause any spark plug to slowly erode, the spark plugs should be removed and checked in accordance with the periodic maintenance and lubrication chart. In addition, the condition of the spark plugs can reveal the condition of the engine.

To remove a spark plug

- 1 Remove the spark plug cap

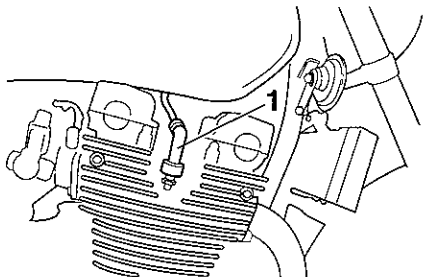

- 1 Spark plug cap

- 2 Remove the spark plug as shown, with the spark plug wrench included in the owner's tool kit

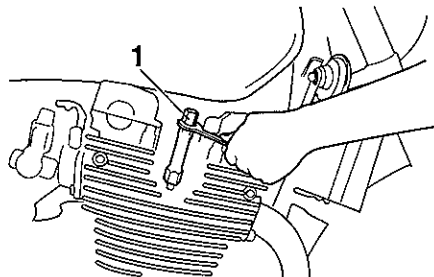

- 1 Spark plug wrench

To check the spark plugs

- 1 Check that the porcelain insulator around the center electrode on each spark plug is a medium-to-light tan (the ideal color when the vehicle is ridden normally).
2. Check that all spark plugs installed in the engine have the same color

NOTE:

If any spark plug shows a distinctly different color, the engine could be defective. Do not attempt to diagnose such problems yourself. Instead, have a Yamaha dealer check the vehicle.

3. Check each spark plug for electrode erosion and excessive carbon or other deposits, and replace it if necessary.

Specified spark plug:

NGK/DPR8EA-9
DENSO/X24EPR-U9

To install a spark plug

- 1 Measure the spark plug gap with a wire thickness gauge and, if necessary, adjust the gap to specification.

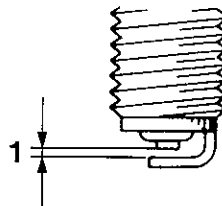

- 1 Spark plug gap

Spark plug gap:

0.8–0.9 mm (0.031–0.035 in)

PERIODIC MAINTENANCE AND MINOR REPAIR

EAU19691

- 2 Clean the surface of the spark plug gasket and its mating surface, and then wipe off any grime from the spark plug threads.
3. Install the spark plug with the spark plug wrench, and then tighten it to the specified torque

Tightening torque:

Spark plug
17.5 Nm (1.75 m·kgf, 13 ft·lbf)

NOTE:

If a torque wrench is not available when installing a spark plug, a good estimate of the correct torque is 1/4–1/2 turn past finger tight. However, the spark plug should be tightened to the specified torque as soon as possible.

- 4 Install the spark plug cap.

Engine oil and oil filter element

The engine oil level should be checked before each ride. In addition, the oil must be changed and the oil filter element replaced at the intervals specified in the periodic maintenance and lubrication chart.

To check the engine oil level

- 1 Place the vehicle on the center-stand

NOTE:

Make sure that the vehicle is positioned straight up when checking the oil level. A slight tilt to the side can result in a false reading.

- 2 Start the engine, warm it up for several minutes, and then turn it off
3. Wait a few minutes until the oil settles, and then check the oil level through the check window located at the bottom-right side of the crankcase.

NOTE:

The engine oil should be between the minimum and maximum level marks.

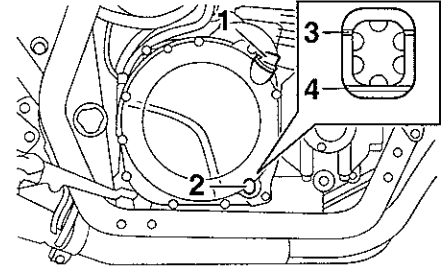

- 1 Engine oil filler cap
- 2 Engine oil level check window
- 3 Maximum level mark
- 4 Minimum level mark

4. If the engine oil is below the minimum level mark, add sufficient oil of the recommended type to raise it to the correct level

To change the engine oil (with or without oil filter element replacement)

1. Start the engine, warm it up for several minutes, and then turn it off

PERIODIC MAINTENANCE AND MINOR REPAIR

- Place an oil pan under the engine to collect the used oil
- Remove the engine oil filler cap and drain bolt to drain the oil from the crankcase.

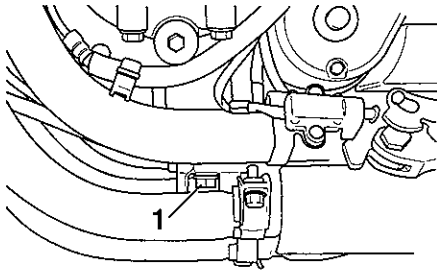

1 Engine oil drain bolt

NOTE:

Skip steps 4–10 if the oil filter element is not being replaced

- Remove panel C. (See page 6-5.)
- Remove the oil filter element drain screw to drain the oil from the oil filter element
- Remove the oil filter element cover by removing the bolt

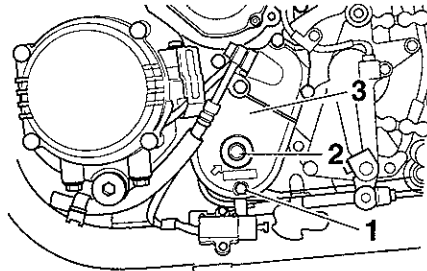

- Oil filter element drain screw
- Bolt
- Oil filter element cover

- Remove and replace the oil filter element and O-ring

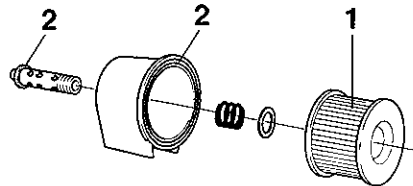

- Oil filter element
- O-ring

- Install the oil filter element cover by aligning the projection on the cover with the slot in the crankcase, installing the bolt, then tightening it to the specified torque

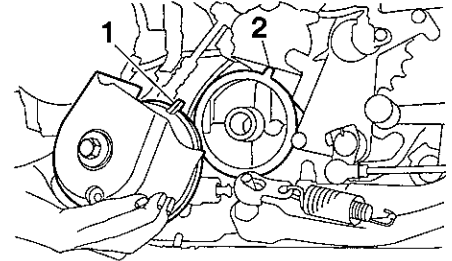

- Projection
- Slot

Tightening torque:

Oil filter element cover bolt
15 Nm (1.5 m·kgf, 11 ft·lbf)

NOTE:

Make sure that the O-ring is properly seated.

- Install the oil filter element drain screw, and then tighten it to the specified torque

PERIODIC MAINTENANCE AND MINOR REPAIR

EAU20610

Tightening torque:

Oil filter element drain screw:
7 Nm (0.7 m·kgf, 5 ft lbf)

10. Install the panel.
11. Install the engine oil drain bolt, and then tighten it to the specified torque.

Tightening torque:

Engine oil drain bolt
43 Nm (4.3 m·kgf, 31 ft lbf)

12. Add the specified amount of the recommended engine oil, and then install and tighten the oil filler cap

Recommended engine oil:

See page 8-1

Oil quantity:

Without oil filter element replacement

3.00 L (3.17 US qt) (2.64 Imp qt)

With oil filter element replacement
3.35 L (3.54 US qt) (2.95 Imp qt)

ECA11620

CAUTION:

- In order to prevent clutch slippage (since the engine oil also lubricates the clutch), do not

mix any chemical additives. Do not use oils with a diesel specification of "CD" or oils of a higher quality than specified. In addition, do not use oils labeled "ENERGY CONSERVING II" or higher.

- Make sure that no foreign material enters the crankcase.

13. Start the engine, and then let it idle for several minutes while checking it for oil leakage. If oil is leaking, immediately turn the engine off and check for the cause.

NOTE:

After the engine is started, the engine oil level warning light should go off if the oil level is sufficient

ECA10400

CAUTION:

If the oil level warning light flickers or remains on, immediately turn the engine off and have a Yamaha dealer check the vehicle.

14. Turn the engine off, and then check the oil level and correct it if necessary.

Cleaning the air filter element

The air filter element should be cleaned at the intervals specified in the periodic maintenance and lubrication chart. Clean the air filter element more frequently if you are riding in unusually wet or dusty areas.

1. Remove the seat (See page 3-14)
2. Remove panel A (See page 6-5)
3. Remove the air filter case cover by removing the screws

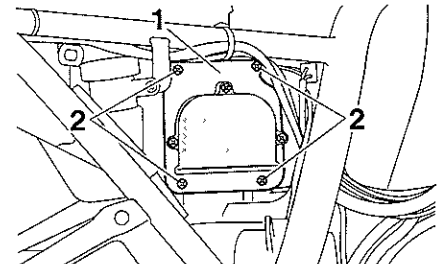

- 1 Air filter case cover
- 2 Screw

4. Pull the air filter element out.

PERIODIC MAINTENANCE AND MINOR REPAIR

ECA10460

EAU21290

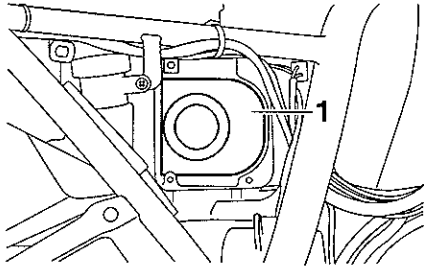

1 Air filter element

5. Lightly tap the air filter element to remove most of the dust and dirt, and then blow the remaining dirt out with compressed air as shown. If the air filter element is damaged, replace it.

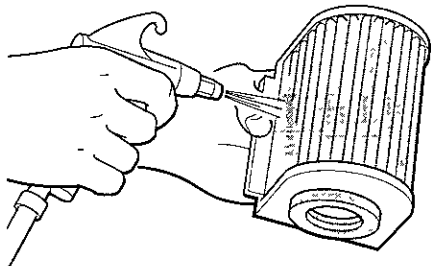

- 6 Insert the air filter element into the air filter case.

CAUTION:

- Make sure that the air filter element is properly seated in the air filter case.
- The engine should never be operated without the air filter element installed, otherwise the piston(s) and/or cylinder(s) may become excessively worn.

- 7 Install the air filter case cover by installing the screws.
- 8 Install the panel and the seat.

Adjusting the carburetors

The carburetors are important parts of the engine and require very sophisticated adjustment. Therefore, most carburetor adjustments should be left to a Yamaha dealer, who has the necessary professional knowledge and experience. The adjustment described in the following section, however, may be serviced by the owner as part of routine maintenance

ECA10560

CAUTION:

The carburetors have been set and extensively tested at the Yamaha factory. Changing these settings without sufficient technical knowledge may result in poor performance of or damage to the engine.

PERIODIC MAINTENANCE AND MINOR REPAIR

EAU21320

Adjusting the engine idling speed

The engine idling speed must be checked and, if necessary, adjusted as follows at the intervals specified in the periodic maintenance and lubrication chart.

The engine should be warm before making this adjustment.

NOTE:

The engine is warm when it quickly responds to the throttle

Check the engine idling speed and, if necessary, adjust it to specification by turning the throttle stop screw. To increase the engine idling speed, turn the screw in direction (a). To decrease the engine idling speed, turn the screw in direction (b)

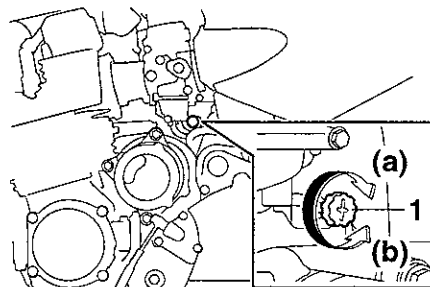

1 Throttle stop screw

Engine idling speed:
950–1150 r/min

NOTE:

If the specified idling speed cannot be obtained as described above, have a Yamaha dealer make the adjustment.

EAU21380

Adjusting the throttle cable free play

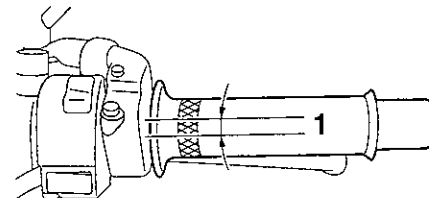

1 Throttle cable free play

The throttle cable free play should measure 3.0–5.0 mm (0.12–0.20 in) at the throttle grip. Periodically check the throttle cable free play and, if necessary, have a Yamaha dealer adjust it

PERIODIC MAINTENANCE AND MINOR REPAIR

EAU21400

Adjusting the valve clearance

The valve clearance changes with use, resulting in improper air-fuel mixture and/or engine noise. To prevent this from occurring, the valve clearance must be adjusted by a Yamaha dealer at the intervals specified in the periodic maintenance and lubrication chart.

EAU21780

Tires

To maximize the performance, durability, and safe operation of your motorcycle, note the following points regarding the specified tires.

Tire air pressure

The tire air pressure should be checked and, if necessary, adjusted before each ride.

EWA10500

WARNING

- The tire air pressure must be checked and adjusted on cold tires (i.e., when the temperature of the tires equals the ambient temperature).
- The tire air pressure must be adjusted in accordance with the riding speed and with the total weight of rider, passenger, cargo, and accessories approved for this model.

Tire air pressure (measured on cold tires):

0–90 kg (0–198 lb):

Front

250 kPa (36 psi) (2.50 kgf/cm²)

Rear:

250 kPa (36 psi) (2.50 kgf/cm²)

90–203 kg (198–448 lb):

Front

250 kPa (36 psi) (2.50 kgf/cm²)

Rear

290 kPa (42 psi) (2.90 kgf/cm²)

High-speed riding:

Front

250 kPa (36 psi) (2.50 kgf/cm²)

Rear

290 kPa (42 psi) (2.90 kgf/cm²)

Maximum load*:

203 kg (448 lb)

* Total weight of rider, passenger, cargo and accessories

EWA10510

WARNING

Proper loading of your vehicle is important for several characteristics of your vehicle, such as handling, braking, performance and safety. Do not carry loosely packed items that can shift. Securely pack your heaviest items close to the center of the vehicle, and distribute the weight

PERIODIC MAINTENANCE AND MINOR REPAIR

evenly from side to side. Properly adjust the suspension for your load, and check the condition and pressure of your tires. **NEVER OVERLOAD YOUR VEHICLE.** Make sure that the total weight of the cargo, rider, passenger, and accessories (cowling, saddlebags, etc. if approved for this model) does not exceed the maximum load of the vehicle. Operation of an overloaded vehicle could cause tire damage, an accident, or even injury.

Tire inspection

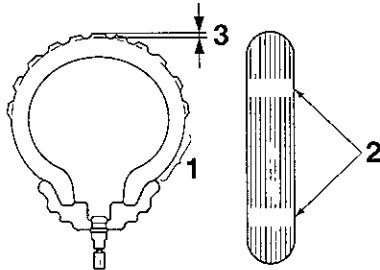

- 1 Tire sidewall
- 2 Tire wear indicator
- 3 Tire tread depth

Always check the tires before operating the motorcycle. If a tire tread shows crosswise lines (minimum tread depth), if the tire has a nail or glass fragments in it, or if the sidewall is cracked, contact a Yamaha dealer immediately and have the tire replaced

EWA10470

! WARNING

- Have a Yamaha dealer replace excessively worn tires. Besides being illegal, operating the vehicle with excessively worn tires decreases riding stability and can lead to loss of control.
- The replacement of all wheel and brake related parts, including the tires, should be left to a Yamaha dealer, who has the necessary professional knowledge and experience.

Minimum tire tread depth (front and rear):

1.0 mm (0.04 in)

NOTE:

The tire tread depth limits may differ from country to country. Always comply with the local regulations.

Tire information

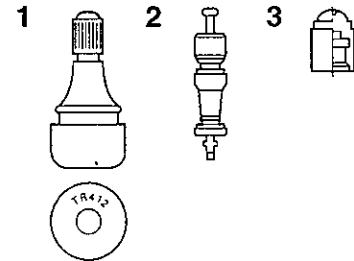

- 1 Tire air valve
- 2 Tire air valve core
- 3 Tire air valve cap with seal

This motorcycle is equipped with cast wheels and tubeless tires with valves

EWA10480

! WARNING

- The front and rear tires should be of the same make and design, otherwise the handling characteristics of the motorcycle cannot be guaranteed.

PERIODIC MAINTENANCE AND MINOR REPAIR

- After extensive tests, only the tires listed below have been approved for this model by Yamaha Motor Co., Ltd.
- Always make sure that the valve caps are securely installed to prevent air pressure leakage.
- Use only the tire valves and valve cores listed below to avoid tire deflation during a high-speed ride.

Front tire:

Size

120/70 ZR17M/C (58W)

Manufacturer/model
DUNLOP/D252FJ

Rear tire:

Size:

180/55 ZR17M/C (73W)

Manufacturer/model
DUNLOP/D252J

FRONT and REAR:

Tire air valve
TR412

Valve core
#9000A (original)

EWA10600

WARNING

This motorcycle is fitted with super-high-speed tires. Note the following points in order to make the most efficient use of these tires.

- Use only the specified replacement tires. Other tires may run the danger of bursting at super high speeds.
- Brand-new tires can have a relatively poor grip on certain road surfaces until they have been “broken in”. Therefore, it is advisable before doing any high-speed riding to ride conservatively for approximately 100 km (60 mi) after installing a new tire.
- The tires must be warmed up before a high-speed run.
- Always adjust the tire air pressure according to the operating conditions.

EAU21960

Cast wheels

To maximize the performance, durability, and safe operation of your vehicle, note the following points regarding the specified wheels.

- The wheel rims should be checked for cracks, bends or warpage before each ride. If any damage is found, have a Yamaha dealer replace the wheel. Do not attempt even the smallest repair to the wheel. A deformed or cracked wheel must be replaced.
- The wheel should be balanced whenever either the tire or wheel has been changed or replaced. An unbalanced wheel can result in poor performance, adverse handling characteristics, and a shortened tire life.
- Ride at moderate speeds after changing a tire since the tire surface must first be “broken in” for it to develop its optimal characteristics.

PERIODIC MAINTENANCE AND MINOR REPAIR

Clutch lever free play

EAU22071

Since this model is equipped with a hydraulic clutch, adjusting the clutch lever free play is not needed. However, it is necessary to check the clutch fluid level and check the hydraulic system for leakage before each ride. If the clutch lever free play does become excessive, and shifting becomes rough or clutch slippage occurs, causing poor acceleration, there may be air in the clutch system. If there is air in the hydraulic system, have a Yamaha dealer bleed the system before operating the motorcycle.

Adjusting the brake pedal position

EAU22240

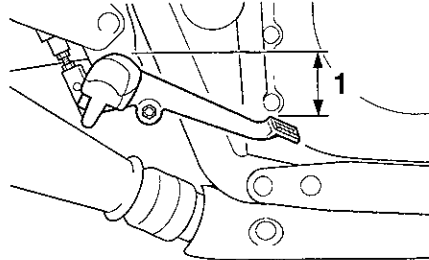

1 Distance between brake pedal and footrest

The top of the brake pedal should be positioned approximately 40.0 mm (1.57 in) below the top of the footrest as shown. Periodically check the brake pedal position and, if necessary, have a Yamaha dealer adjust it.

EWA10690

⚠ WARNING

A soft or spongy feeling in the brake pedal can indicate the presence of air in the hydraulic system. If there is air in the hydraulic system, have a Yamaha dealer bleed the system before operating the motorcycle. Air in the hydraulic system will diminish

the braking performance, which may result in loss of control and an accident.

PERIODIC MAINTENANCE AND MINOR REPAIR

Rear brake light switch adjustment

EAU22290

3 Install the panel

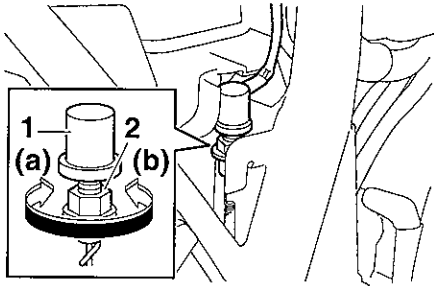

- 1 Rear brake light switch
- 2 Rear brake light switch adjusting nut

6 The rear brake light switch, which is activated by the brake pedal, is properly adjusted when the brake light comes on just before braking takes effect. If necessary, adjust the brake light switch as follows.

1. Remove panel A (See page 6-5.)
2. Turn the adjusting nut while holding the rear brake light switch in place. To make the brake light come on earlier, turn the adjusting nut in direction (a). To make the brake light come on later, turn the adjusting nut in direction (b).

Checking the front and rear brake pads

EAU22321

Front brake

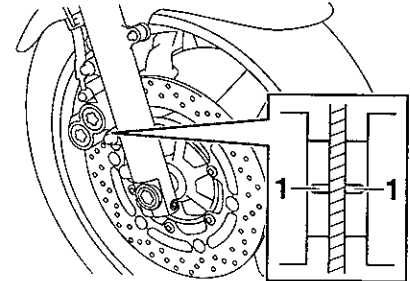

- 1 Brake pad wear indicator groove

Rear brake

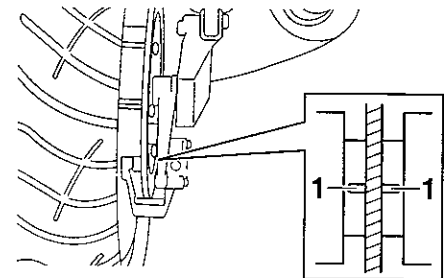

- 1 Brake pad wear indicator groove

PERIODIC MAINTENANCE AND MINOR REPAIR

The front and rear brake pads must be checked for wear at the intervals specified in the periodic maintenance and lubrication chart. Each brake pad is provided with a wear indicator groove, which allows you to check the brake pad wear without having to disassemble the brake. To check the brake pad wear, check the wear indicator grooves. If a brake pad has worn to the point that the wear indicator groove has almost disappeared, have a Yamaha dealer replace the brake pads as a set.

Checking the brake and clutch fluid levels

EAU22680

Front brake

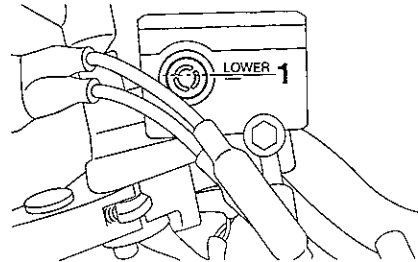

1 Minimum level mark

Rear brake

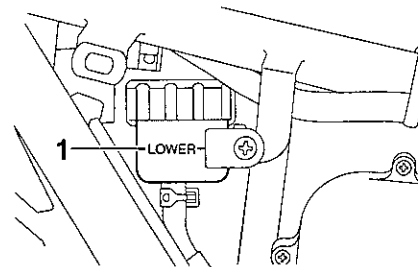

1 Minimum level mark

Clutch

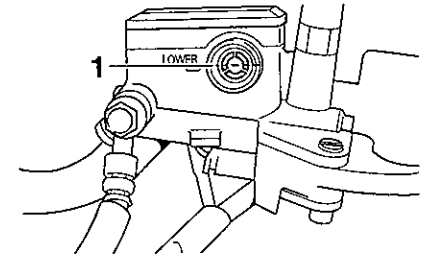

1 Minimum level mark

Insufficient brake fluid may allow air to enter the brake or clutch systems, possibly causing them to become ineffective.

Before riding, check that the brake fluid is above the minimum level mark and replenish if necessary. A low brake fluid level may indicate worn brake pads and/or brake system leakage. If the brake level is low, be sure to check the brake pads for wear and the brake system for leakage.

NOTE:

The rear brake fluid reservoir is located behind panel A. (See page 6-5.)

Observe these precautions:

PERIODIC MAINTENANCE AND MINOR REPAIR

- When checking the fluid level, make sure that the top of the brake or clutch fluid reservoir is level
- Use only the recommended quality brake fluid, otherwise the rubber seals may deteriorate, causing leakage and poor braking or clutch performance

Recommended brake and clutch fluid:

DOT 4 brake fluid

- Refill with the same type of brake fluid. Mixing fluids may result in a harmful chemical reaction and lead to poor braking or clutch performance.
- The brake or clutch fluid reservoir diaphragm will lose its shape from the negative pressure if the fluid level goes down too far. Be sure to return the diaphragm to its original shape before installing it into the brake or clutch fluid reservoir.
- Be careful that water does not enter the brake or clutch fluid reservoir when refilling. Water will

significantly lower the boiling point of the fluid and may result in vapor lock

- Brake fluid may deteriorate painted surfaces or plastic parts. Always clean up spilled fluid immediately.
- As the brake pads wear, it is normal for the brake fluid level to gradually go down. However, if the brake fluid level goes down suddenly, have a Yamaha dealer check the cause

Changing the brake and clutch fluids

EAU22750

Have a Yamaha dealer change the brake and clutch fluids at the intervals specified in the NOTE after the periodic maintenance and lubrication chart. In addition, have the oil seals of the brake and clutch master cylinders and calipers as well as the brake and clutch hoses replaced at the intervals listed below or whenever they are damaged or leaking

- Oil seals: Replace every two years.
- Brake and clutch hoses: Replace every four years.

PERIODIC MAINTENANCE AND MINOR REPAIR

Drive chain slack

EAU22760

The drive chain slack should be checked before each ride and adjusted if necessary

To check the drive chain slack

EAU22791

1. Place the motorcycle on the centerstand
2. Shift the transmission into the neutral position.
3. Spin the rear wheel several times to locate the tightest portion of the drive chain
4. Measure the drive chain slack as shown

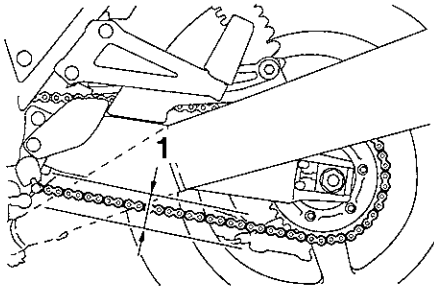

1 Drive chain slack

Drive chain slack:

20 0–30 0 mm (0 79–1 18 in)

5. If the drive chain slack is incorrect, adjust it as follows

To adjust the drive chain slack

EAU22940

1. Loosen the axle nut and the locknut on each side of the swingarm
2. To tighten the drive chain, turn the adjusting bolt on each side of the swingarm in direction (a). To loosen the drive chain, turn the adjusting bolt on each side of the swingarm in direction (b), and then push the rear wheel forward

NOTE:

Using the alignment marks on each side of the swingarm, make sure that both chain pullers are in the same position for proper wheel alignment

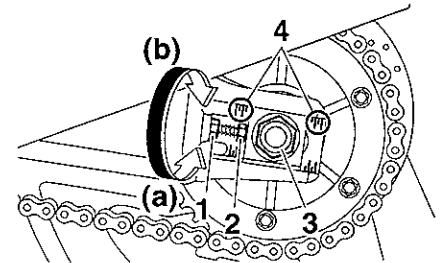

- 1 Locknut
- 2 Drive chain slack adjusting bolt
- 3 Axle nut
- 4 Alignment marks

ECA10570

CAUTION:

Improper drive chain slack will overload the engine as well as other vital parts of the motorcycle and can lead to chain slippage or breakage. To prevent this from occurring, keep the drive chain slack within the specified limits.

3. Tighten the locknuts, and then tighten the axle nut to the specified torque

PERIODIC MAINTENANCE AND MINOR REPAIR

Tightening torque:

Axle nut

150 Nm (15.0 m·kgf, 108 ft·lbf)

Lubricating the drive chain

EAU23021

The drive chain must be cleaned and lubricated at the intervals specified in the periodic maintenance and lubrication chart, otherwise it will quickly wear out, especially when riding in dusty or wet areas. Service the drive chain as follows

CAUTION:

The drive chain must be lubricated after washing the motorcycle and riding in the rain.

- 1 Clean the drive chain with kerosene and a small soft brush

CAUTION:

To prevent damaging the O-rings, do not clean the drive chain with steam cleaners, high-pressure washers or inappropriate solvents.

- 2 Wipe the drive chain dry
- 3 Thoroughly lubricate the drive chain with a special O-ring chain lubricant

CAUTION:

Do not use engine oil or any other lubricants for the drive chain, as they may contain substances that could damage the O-rings.

ECA11110

ECA10581

ECA11120

PERIODIC MAINTENANCE AND MINOR REPAIR

Checking and lubricating the cables

EAU23100

The operation of all control cables and the condition of the cables should be checked before each ride, and the cables and cable ends should be lubricated if necessary. If a cable is damaged or does not move smoothly, have a Yamaha dealer check or replace it.

Recommended lubricant:

Engine oil

EWA10720

⚠ WARNING

Damage to the outer sheath may interfere with proper cable operation and will cause the inner cable to rust. Replace a damaged cable as soon as possible to prevent unsafe conditions.

Checking and lubricating the throttle grip and cable

EAU23110

The operation of the throttle grip should be checked before each ride. In addition, the cable should be lubricated or replaced at the intervals specified in the periodic maintenance chart.

Checking and lubricating the brake and shift pedals

EAU23131

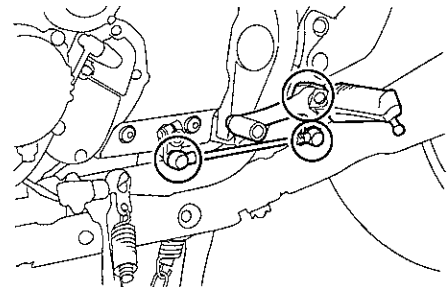
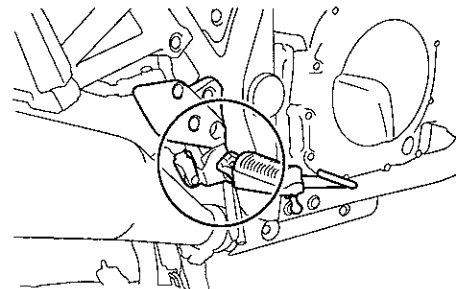

The operation of the brake and shift pedals should be checked before each ride, and the pedal pivots should be lubricated if necessary.

PERIODIC MAINTENANCE AND MINOR REPAIR

Recommended lubricant:

Lithium-soap-based grease (all-purpose grease)

Checking and lubricating the brake and clutch levers

EAU23140

Recommended lubricant:

Lithium-soap-based grease (all-purpose grease)

Brake lever

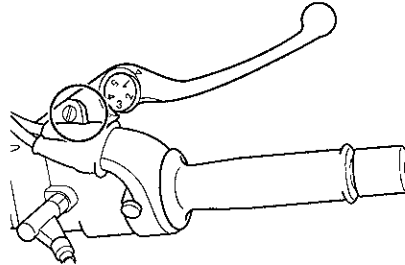

Clutch lever

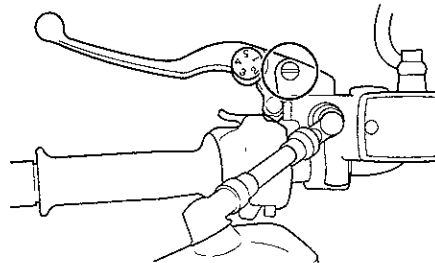

The operation of the brake and clutch levers should be checked before each ride, and the lever pivots should be lubricated if necessary.

PERIODIC MAINTENANCE AND MINOR REPAIR

Checking and lubricating the centerstand and sidestand

EAU23210

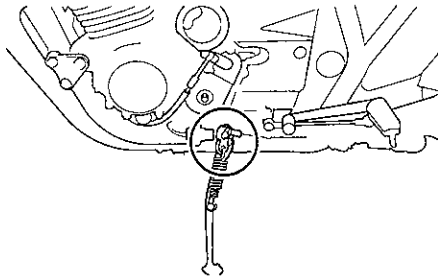
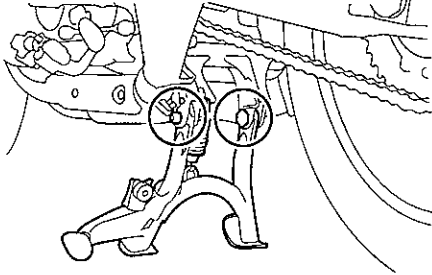

The operation of the centerstand and sidestand should be checked before each ride, and the pivots and metal-to-metal contact surfaces should be lubricated if necessary.

⚠ WARNING

If the centerstand or sidestand does not move up and down smoothly, have a Yamaha dealer check or repair it.

EWA10740

Recommended lubricant:
Lithium-soap-based grease (all-purpose grease)

Checking the front fork

EAU23271

The condition and operation of the front fork must be checked as follows at the intervals specified in the periodic maintenance and lubrication chart

To check the condition

EWA10750

⚠ WARNING

Securely support the vehicle so that there is no danger of it falling over.

Check the inner tubes for scratches, damage and excessive oil leakage.

To check the operation

- 1 Place the vehicle on a level surface and hold it in an upright position
- 2 While applying the front brake, push down hard on the handlebars several times to check if the front fork compresses and rebounds smoothly

PERIODIC MAINTENANCE AND MINOR REPAIR

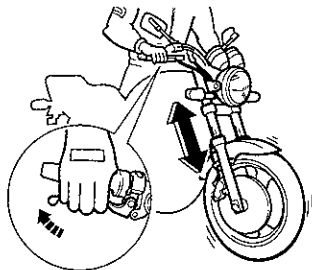

ECA10590

CAUTION:

If any damage is found or the front fork does not operate smoothly, have a Yamaha dealer check or repair it.

6

Checking the steering

EAU23280

Worn or loose steering bearings may cause danger. Therefore, the operation of the steering must be checked as follows at the intervals specified in the periodic maintenance and lubrication chart.

1. Place a stand under the engine to raise the front wheel off the ground.

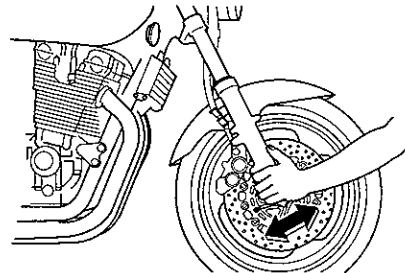

EWA10750

! WARNING

Securely support the vehicle so that there is no danger of it falling over.

2. Hold the lower ends of the front fork legs and try to move them forward and backward. If any free play can be felt, have a Yamaha dealer check or repair the steering.

PERIODIC MAINTENANCE AND MINOR REPAIR

Checking the wheel bearings

EAU23290

The front and rear wheel bearings must be checked at the intervals specified in the periodic maintenance and lubrication chart. If there is play in the wheel hub or if the wheel does not turn smoothly, have a Yamaha dealer check the wheel bearings.

Battery

EAU33650

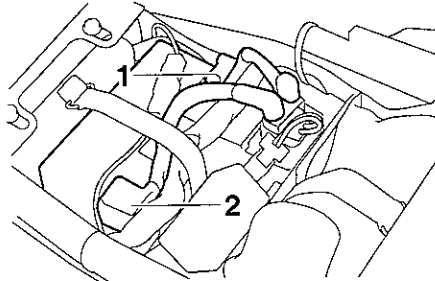

- 1 Negative battery terminal
- 2 Positive battery terminal

This model is equipped with a sealed-type (MF) battery, which does not require any maintenance. There is no need to check the electrolyte or to add distilled water.

EWA10760

WARNING

- **Electrolyte is poisonous and dangerous since it contains sulfuric acid, which causes severe burns. Avoid any contact with skin, eyes or clothing and always shield your eyes when**

working near batteries. In case of contact, administer the following **FIRST AID**.

- **EXTERNAL:** Flush with plenty of water.
- **INTERNAL:** Drink large quantities of water or milk and immediately call a physician.
- **EYES:** Flush with water for 15 minutes and seek prompt medical attention.
- **Batteries produce explosive hydrogen gas. Therefore, keep sparks, flames, cigarettes, etc., away from the battery and provide sufficient ventilation when charging it in an enclosed space.**
- **KEEP THIS AND ALL BATTERIES OUT OF THE REACH OF CHILDREN.**

To charge the battery

Have a Yamaha dealer charge the battery as soon as possible if it seems to have discharged. Keep in mind that the

PERIODIC MAINTENANCE AND MINOR REPAIR

battery tends to discharge more quickly if the vehicle is equipped with optional electrical accessories.

To store the battery

1. If the vehicle will not be used for more than one month, remove the battery, fully charge it, and then place it in a cool, dry place.
2. If the battery will be stored for more than two months, check it at least once a month and fully charge it if necessary.
3. Fully charge the battery before installation.
4. After installation, make sure that the battery leads are properly connected to the battery terminals.

ECA10630

CAUTION

- Always keep the battery charged. Storing a discharged battery can cause permanent battery damage.
- To charge a sealed-type (MF) battery, a special (constant-voltage) battery charger is required. Using a conventional battery charger will damage the battery.

If you do not have access to a sealed-type (MF) battery charger, have a Yamaha dealer charge your battery.

Replacing the fuses

EAU33581

The fuse box, which contains the fuses for the individual circuits, is located under the seat. (See page 3-14.)

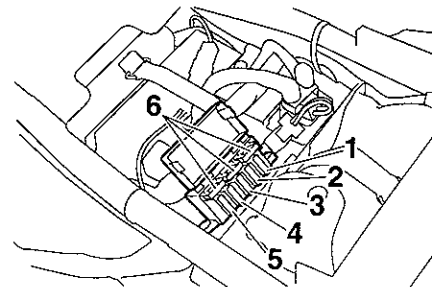

- 1 Backup fuse (for odometer, clock and immobilizer system)
- 2 Ignition fuse
- 3 Headlight fuse
- 4 Signaling system fuse
- 5 Main fuse
- 6 Spare fuse

The parking lighting fuse is located behind panel B. (See page 6-5)

PERIODIC MAINTENANCE AND MINOR REPAIR

ECA10640

EAU23792

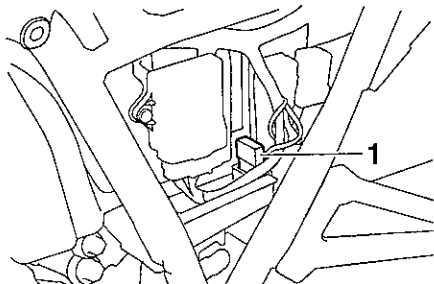

1 Parking lighting fuse

If a fuse is blown, replace it as follows

1. Turn the key to "OFF" and turn off the electrical circuit in question
2. Remove the blown fuse, and then install a new fuse of the specified amperage

Specified fuses:

- Main fuse
40 0 A
- Headlight fuse^{*}
15 0 A
- Signaling system fuse
10 0 A
- Ignition fuse
15 0 A
- Backup fuse
10 0 A
- Parking lighting fuse
10 0 A

CAUTION

Do not use a fuse of a higher amperage rating than recommended to avoid causing extensive damage to the electrical system and possibly a fire.

3. Turn the key to "ON" and turn on the electrical circuit in question to check if the device operates.
4. If the fuse immediately blows again, have a Yamaha dealer check the electrical system

Replacing the headlight bulb

This model is equipped with a quartz bulb headlight. If the headlight bulb burns out, replace it as follows.

- 1 Remove the headlight unit by removing the screws

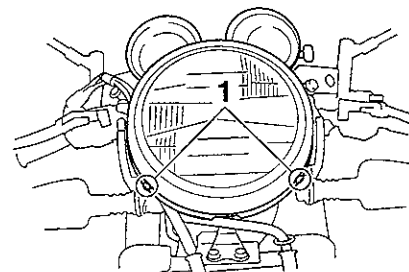

1 Screw

2. Disconnect the headlight coupler, and then remove the bulb cover.

PERIODIC MAINTENANCE AND MINOR REPAIR

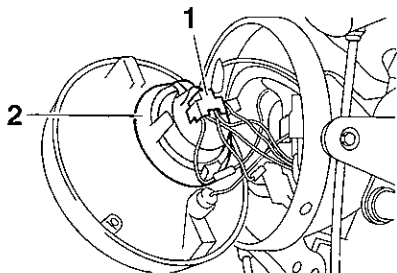

- 1 Headlight coupler
- 2 Headlight bulb holder

3. Unhook the headlight bulb holder, and then remove the defective bulb

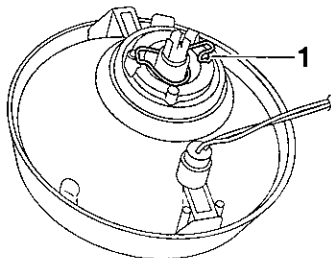

- 1 Headlight bulb holder

! WARNING

EWA10790

Headlight bulbs get very hot. Therefore, keep flammable products away from a lit headlight bulb, and do not touch the bulb until it has cooled down.

- 4 Place a new headlight bulb into position, and then secure it with the bulb holder.

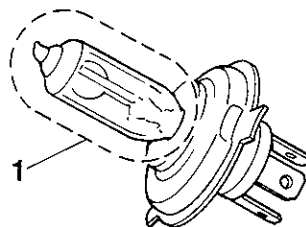

- 1 Do not touch the glass part of the bulb

CAUTION:

ECA10660

Do not touch the glass part of the headlight bulb to keep it free from oil, otherwise the transparency of the glass, the luminosity of the bulb, and the bulb life will be adversely af-

ected. Thoroughly clean off any dirt and fingerprints on the headlight bulb using a cloth moistened with alcohol or thinner.

- 5 Install the headlight bulb cover, and then connect the coupler.
6. Install the headlight unit by installing the screws
7. Have a Yamaha dealer adjust the headlight beam if necessary

PERIODIC MAINTENANCE AND MINOR REPAIR

EAU24170

Replacing a tail/brake light bulb

- 1 Remove the seat. (See page 3-14.)
- 2 Remove the socket (together with the bulb) by turning it counter-clockwise

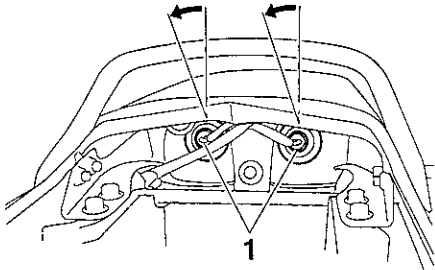

1 Tail/brake light bulb socket

- 3 Remove the defective bulb by pushing it in and turning it counter-clockwise.
- 4 Insert a new bulb into the socket, push it in, and then turn it clockwise until it stops
- 5 Install the socket (together with the bulb) by turning it clockwise.
- 6 Install the seat

EAU24201

Replacing a turn signal light bulb

- 1 Remove the turn signal light lens by removing the screw

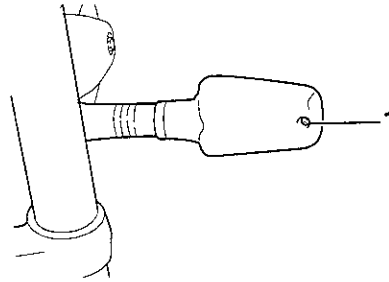

1 Screw

- 2 Remove the defective bulb by pushing it in and turning it counter-clockwise.

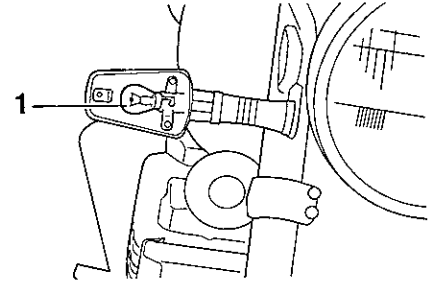

1 Turn signal light bulb

- 3 Insert a new bulb into the socket, push it in, and then turn it clockwise until it stops
- 4 Install the lens by installing the screw.

ECA11190

CAUTION:

Do not overtighten the screw, otherwise the lens may break.

PERIODIC MAINTENANCE AND MINOR REPAIR

Replacing the auxiliary light bulb

EAU33541

If the auxiliary light bulb burns out, replace it as follows.

1. Remove the headlight unit by removing the screws

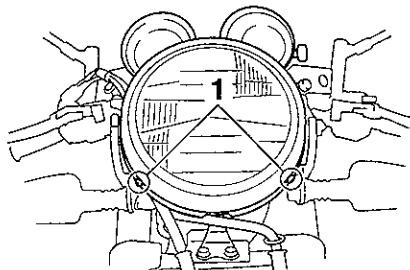

1 Screw

2. Remove the socket (together with the bulb) by pulling it out

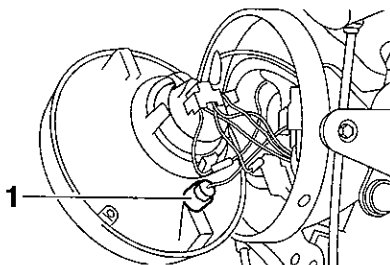

1 Auxiliary light bulb socket

3. Remove the defective bulb by pushing it in and turning it counter-clockwise
4. Insert a new bulb into the socket, push it in, and then turn it clockwise until it stops
5. Install the socket (together with the bulb) by pushing it in.
6. Install the headlight unit by installing the screws.

Front wheel

EAU24380

To remove the front wheel

EAU33680

EWA10820

WARNING

- It is advisable to have a Yamaha dealer service the wheel.
- Securely support the motorcycle so that there is no danger of it falling over.

- 1 Place the motorcycle on the centerstand.
- 2 Loosen the front wheel axle pinch bolt, then the wheel axle and the brake caliper bolts

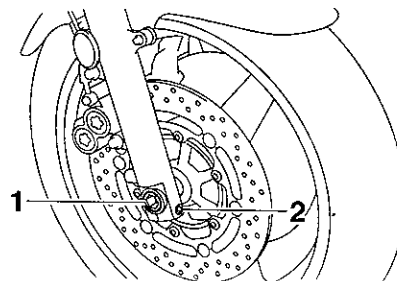

1 Wheel axle

2 Front wheel axle pinch bolt

PERIODIC MAINTENANCE AND MINOR REPAIR

3. Remove the brake hose holder and reflector on each side by removing the bolts.
4. Remove the brake caliper on each side by removing the bolts

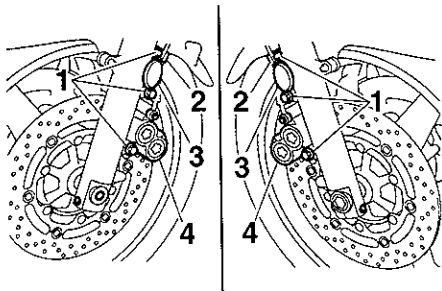

- 1 Bolt
- 2 Brake hose holder
- 3 Reflector
- 4 Brake caliper

ECA11050

CAUTION

Do not apply the brake after the brake calipers have been removed, otherwise the brake pads will be forced shut.

5. Pull the wheel axle out, and then remove the wheel.

EAU33770

To install the front wheel

1. Lift the wheel up between the fork legs.
2. Insert the wheel axle.
3. Install the brake calipers by installing the bolts

NOTE:

Make sure that there is enough space between the brake pads before installing the brake calipers onto the brake discs.

4. Install the brake hose holders and reflectors by installing the bolts.
5. Take the motorcycle off the center-stand so that the front wheel is on the ground.
6. Tighten the wheel axle, the front wheel axle pinch bolt and the brake caliper bolts to the specified torques.

Tightening torques:

Wheel axle

72 Nm (7.2 m·kgf, 52 ft·lbf)

Front wheel axle pinch bolt

20 Nm (2.0 m·kgf, 14.5 ft·lbf)

Brake caliper bolt.

40 Nm (4.0 m·kgf, 29 ft·lbf)

7. Push down hard on the handlebar several times to check for proper fork operation.

PERIODIC MAINTENANCE AND MINOR REPAIR

Rear wheel

EAU25080

To remove the rear wheel

EAU25160

EWA10820

WARNING

- It is advisable to have a Yamaha dealer service the wheel.
- Securely support the motorcycle so that there is no danger of it falling over.

1. Loosen the axle nut and the brake caliper bolts

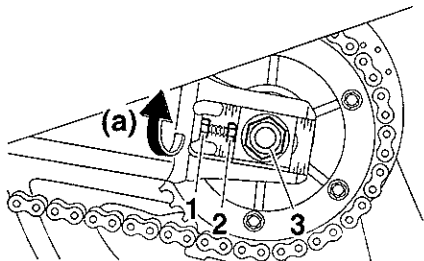

- 1 Locknut
- 2 Drive chain slack adjusting bolt
- 3 Axle nut

- 2 Disconnect the brake torque rod from the brake caliper bracket by removing the nut and the bolt.

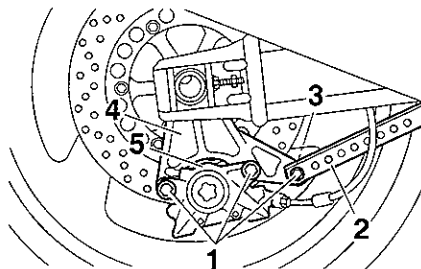

- 1 Bolt
- 2 Brake torque rod
- 3 Nut
- 4 Brake caliper bracket
- 5 Brake caliper

3. Place the motorcycle on the centerstand.
4. Remove the axle nut and the brake caliper by removing the bolts.

CAUTION:

Do not apply the brake after the brake caliper has been removed, otherwise the brake pads will be forced shut.

ECA11300

- 5 Loosen the locknuts, and then turn the drive chain slack adjusting bolt on each side of the swingarm fully in direction (a).

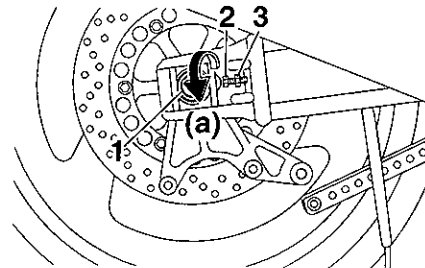

- 1 Wheel axle
- 2 Drive chain slack adjusting bolt
- 3 Locknut

6. Push the wheel forward, and then remove the drive chain from the rear sprocket

NOTE:

The drive chain does not need to be disassembled in order to remove and install the rear wheel.

- 7 While supporting the wheel and the brake caliper bracket, pull the wheel axle out

PERIODIC MAINTENANCE AND MINOR REPAIR

EAU25850

- 8 Remove the brake caliper bracket and the wheel.

EAU25841

To install the rear wheel

- 1 Place the wheel and the brake caliper bracket in the original position
- 2 Insert the wheel axle through the brake caliper bracket and wheel from the right-hand side, and then install the axle nut
- 3 Install the drive chain onto the rear sprocket, and then adjust the drive chain slack (See page 6-20)
- 4 Connect the brake torque rod to the brake caliper bracket by installing the bolt and the nut
- 5 Install the brake caliper by installing the bolts.

NOTE:

Make sure that there is enough space between the brake pads before installing the brake caliper onto the brake disc

- 6 Take the motorcycle off the center-stand so that the rear wheel is on the ground.

- 7 Tighten the axle nut, brake caliper bolts and brake torque rod nut to the specified torques.

Tightening torques:

- Axle nut
150 Nm (15.0 m kgf, 108 ft-lbf)
- Brake caliper bolt
40 Nm (4.0 m kgf, 29 ft lbf)
- Brake torque rod nut
23 Nm (2.3 m kgf, 17 ft lbf)

Troubleshooting

Although Yamaha motorcycles receive a thorough inspection before shipment from the factory, trouble may occur during operation. Any problem in the fuel, compression, or ignition systems, for example, can cause poor starting and loss of power.

The following troubleshooting chart represents a quick and easy procedure for checking these vital systems yourself. However, should your motorcycle require any repair, take it to a Yamaha dealer, whose skilled technicians have the necessary tools, experience, and know-how to service the motorcycle properly.

Use only genuine Yamaha replacement parts. Imitation parts may look like Yamaha parts, but they are often inferior, have a shorter service life and can lead to expensive repair bills.

PERIODIC MAINTENANCE AND MINOR REPAIR

Troubleshooting chart

EAU25891



WARNING

EWA10840

Keep away open flames and do not smoke while checking or working on the fuel system.

1. Fuel

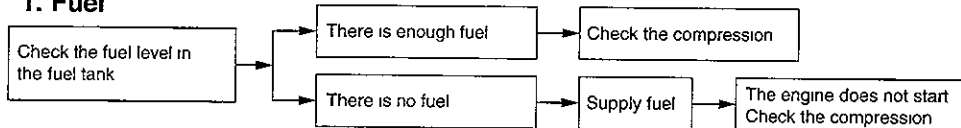

2. Compression

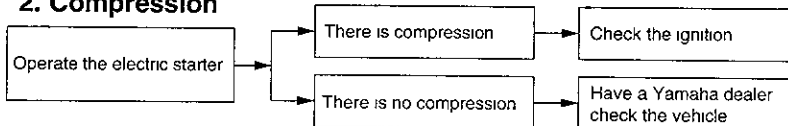

3. Ignition

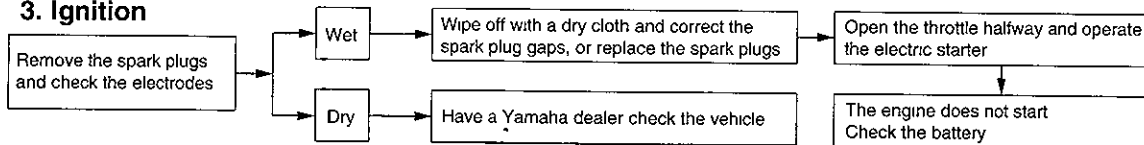

4. Battery

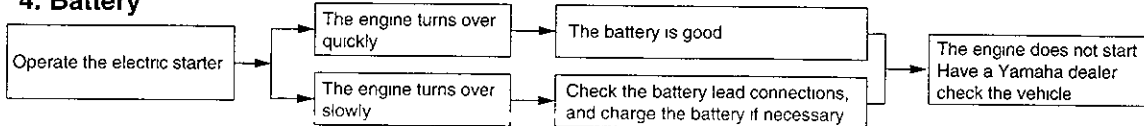

MOTORCYCLE CARE AND STORAGE

Care

EAU26040

While the open design of a motorcycle reveals the attractiveness of the technology, it also makes it more vulnerable. Rust and corrosion can develop even if high-quality components are used. A rusty exhaust pipe may go unnoticed on a car, however, it detracts from the overall appearance of a motorcycle. Frequent and proper care does not only comply with the terms of the warranty, but it will also keep your motorcycle looking good, extend its life and optimize its performance.

Before cleaning

1. Cover the muffler outlets with plastic bags after the engine has cooled down.
2. Make sure that all caps and covers as well as all electrical couplers and connectors, including the spark plug caps, are tightly installed
3. Remove extremely stubborn dirt, like oil burnt onto the crankcase, with a degreasing agent and a brush, but never apply such prod-

ucts onto seals, gaskets, sprockets, the drive chain and wheel axles. Always rinse the dirt and degreaser off with water.

Cleaning

ECA10770

CAUTION:

- Avoid using strong acidic wheel cleaners, especially on spoked wheels. If such products are used on hard-to-remove dirt, do not leave the cleaner on the affected area any longer than instructed. Also, thoroughly rinse the area off with water, immediately dry it, and then apply a corrosion protection spray.
- Improper cleaning can damage windshields, cowlings, panels and other plastic parts. Use only a soft, clean cloth or sponge with mild detergent and water to clean plastic.
- Do not use any harsh chemical products on plastic parts. Be sure to avoid using cloths or sponges which have been in contact with strong or abrasive

cleaning products, solvent or thinner, fuel (gasoline), rust removers or inhibitors, brake fluid, antifreeze or electrolyte.

- Do not use high-pressure washers or steam-jet cleaners since they cause water seepage and deterioration in the following areas: seals (of wheel and swing-arm bearings, fork and brakes), electric components (couplers, connectors, instruments, switches and lights), breather hoses and vents.
- For motorcycles equipped with a windshield: Do not use strong cleaners or hard sponges as they will cause dulling or scratching. Some cleaning compounds for plastic may leave scratches on the windshield. Test the product on a small hidden part of the windshield to make sure that it does not leave any marks. If the windshield is scratched, use a quality plastic polishing compound after washing.

MOTORCYCLE CARE AND STORAGE

After normal use

Remove dirt with warm water, a mild detergent, and a soft, clean sponge, and then rinse thoroughly with clean water. Use a toothbrush or bottlebrush for hard-to-reach areas. Stubborn dirt and insects will come off more easily if the area is covered with a wet cloth for a few minutes before cleaning.

After riding in the rain, near the sea or on salt-sprayed roads

Since sea salt or salt sprayed on roads during winter are extremely corrosive in combination with water, carry out the following steps after each ride in the rain, near the sea or on salt-sprayed roads.

NOTE:

Salt sprayed on roads in the winter may remain well into spring.

- 1 Clean the motorcycle with cold water and a mild detergent, after the engine has cooled down

CAUTION:

Do not use warm water since it increases the corrosive action of the salt.

- 2 After drying the motorcycle, apply a corrosion protection spray on all metal, including chrome- and nickel-plated, surfaces to prevent corrosion

After cleaning

- 1 Dry the motorcycle with a chamois or an absorbing cloth
- 2 Immediately dry the drive chain and lubricate it to prevent it from rusting
- 3 Use a chrome polish to shine chrome, aluminum and stainless-steel parts, including the exhaust system (Even the thermally induced discoloring of stainless-steel exhaust systems can be removed through polishing)

ECA10790

4. To prevent corrosion, it is recommended to apply a corrosion protection spray on all metal, including chrome- and nickel-plated, surfaces
5. Use spray oil as a universal cleaner to remove any remaining dirt
6. Touch up minor paint damage caused by stones, etc.
- 7 Wax all painted surfaces
8. Let the motorcycle dry completely before storing or covering it.

WARNING

- **Make sure that there is no oil or wax on the brakes or tires. If necessary, clean the brake discs and brake linings with a regular brake disc cleaner or acetone, and wash the tires with warm water and a mild detergent.**
- **Before operating the motorcycle test its braking performance and cornering behavior.**

EWA10930

MOTORCYCLE CARE AND STORAGE

ECA10800

CAUTION:

- Apply spray oil and wax sparingly and make sure to wipe off any excess.
- Never apply oil or wax to any rubber and plastic parts, but treat them with a suitable care product.
- Avoid using abrasive polishing compounds as they will wear away the paint.

NOTE:

Consult a Yamaha dealer for advice on what products to use

EAU26211

Storage

Short-term

Always store your motorcycle in a cool, dry place and, if necessary, protect it against dust with a porous cover.

ECA10810

CAUTION:

- Storing the motorcycle in a poorly ventilated room or covering it with a tarp, while it is still wet, will allow water and humidity to seep in and cause rust.
- To prevent corrosion, avoid damp cellars, stables (because of the presence of ammonia) and areas where strong chemicals are stored.

Long-term

Before storing your motorcycle for several months

- 1 Follow all the instructions in the "Care" section of this chapter
2. Turn the fuel cock lever to "ON"

3. Drain the carburetor float chambers by loosening the drain bolts; this will prevent fuel deposits from building up. Pour the drained fuel into the fuel tank.
4. Fill up the fuel tank and add fuel stabilizer (if available) to prevent the fuel tank from rusting and the fuel from deteriorating
5. Perform the following steps to protect the cylinders, piston rings, etc. from corrosion
 - a Remove the spark plug caps and spark plugs.
 - b. Pour a teaspoonful of engine oil into each spark plug bore.
 - c. Install the spark plug caps onto the spark plugs, and then place the spark plugs on the cylinder head so that the electrodes are grounded (This will limit sparking during the next step.)
 - d Turn the engine over several times with the starter (This will coat the cylinder walls with oil.)
 - e. Remove the spark plug caps from the spark plugs, and then install the spark plugs and the spark plug caps

MOTORCYCLE CARE AND STORAGE

EWA10950

WARNING

To prevent damage or injury from sparking, make sure to ground the spark plug electrodes while turning the engine over.

6. Lubricate all control cables and the pivoting points of all levers and pedals as well as of the side-stand/centerstand
- 7 Check and, if necessary, correct the tire air pressure, and then lift the motorcycle so that both of its wheels are off the ground. Alternatively, turn the wheels a little every month in order to prevent the tires from becoming degraded in one spot.
8. Cover the muffler outlets with plastic bags to prevent moisture from entering them
- 9 Remove the battery and fully charge it. Store it in a cool, dry place and charge it once a month. Do not store the battery in an excessively cold or warm place [less than 0 °C (30 °F) or more

than 30 °C (90 °F)] For more information on storing the battery, see page 6-26

NOTE: _____
Make any necessary repairs before storing the motorcycle

SPECIFICATIONS

Dimensions:

Overall length
2175 mm (85 6 in)
Overall width
775 mm (30 5 in)
Overall height
1115 mm (43 9 in)
Seat height
790 mm (31 1 in)
Wheelbase
1510 mm (59 4 in)
Ground clearance
120 mm (4 72 in)
Minimum turning radius
2800 mm (110 2 in)

Weight:

With oil and fuel
247 0 kg (545 lb)

Engine:

Engine type
Air cooled 4-stroke, DOHC
Cylinder arrangement
Forward-inclined parallel 4-cylinder
Displacement
1251 0 cm³ (76 34 cu in)
Bore × stroke
79 0 × 63 8 mm (3 11 × 2 51 in)
Compression ratio
9 70 1
Starting system
Electric starter
Lubrication system
Wet sump

Engine oil:

Type
SAE10W30 or SAE10W40 or SAE15W40
or SAE20W40 or SAE20W50

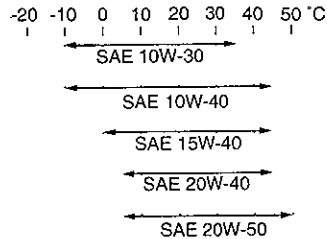

Recommended engine oil grade
API service SE, SF, SG type or higher
Engine oil quantity
Without oil filter element replacement
3 00 L (3 17 US qt) (2 64 Imp qt)
With oil filter element replacement
3 35 L (3 54 US qt) (2 95 Imp qt)

Air filter:

Air filter element
Dry element

Fuel:

Recommended fuel
Unleaded gasoline only
Fuel tank capacity
21 0 L (5 55 US gal) (4 62 Imp gal)
Fuel reserve amount
4 5 L (1 19 US gal) (0 99 Imp gal)

Carburetor:

Manufacturer
MIKUNI
Type x quantity
BSR37 x 4

Spark plug(s):

Manufacturer/model
NGK/DPR8EA-9
Manufacturer/model
DENSO/X24EPR-U9
Spark plug gap
0 8–0 9 mm (0 031–0 035 in)

Clutch:

Clutch type
Wet, multiple-disc

Transmission:

Primary reduction system
Spur gear
Primary reduction ratio
98/56 (1 750)
Secondary reduction system
Chain drive
Secondary reduction ratio
39/18 (2 167)
Transmission type
Constant mesh 5-speed
Operation
Left foot operation
Gear ratio
1st
40/14 (2 857)
2nd
36/18 (2 000)

SPECIFICATIONS

3rd
33/21 (1 571)
4th
31/24 (1 292)
5th
29/26 (1 115)

Chassis:

Frame type
Double cradle
Caster angle
25.5°
Trail
100.0 mm (3.94 in)

Front tire:

Type
Tubeless
Size
120/70 ZR17M/C (58W)
Manufacturer/model
DUNLOP/D252FJ

Rear tire:

Type
Tubeless
Size
180/55 ZR17M/C (73W)
Manufacturer/model
DUNLOP/D252J

Loading:

Maximum load
203 kg (448 lb)
(Total weight of rider, passenger, cargo and accessories)

Tire air pressure (measured on cold tires):

Loading condition
0–90 kg (0–198 lb)
Front
250 kPa (36 psi) (2.50 kgf/cm²)
Rear
250 kPa (36 psi) (2.50 kgf/cm²)
Loading condition
90–203 kg (198–448 lb)
Front
250 kPa (36 psi) (2.50 kgf/cm²)
Rear
290 kPa (42 psi) (2.90 kgf/cm²)
High-speed riding
Front
250 kPa (36 psi) (2.50 kgf/cm²)
Rear
290 kPa (42 psi) (2.90 kgf/cm²)

Front wheel:

Wheel type
Cast wheel
Rim size
17M/C x MT3.50

Rear wheel:

Wheel type
Cast wheel
Rim size
17M/C x MT5.50

Front brake:

Type
Dual disc brake
Operation
Right hand operation

Recommended fluid
DOT 4

Rear brake:

Type
Single disc brake
Operation
Right foot operation
Recommended fluid
DOT 4

Front suspension:

Type
Telescopic fork
Spring/shock absorber type
Coil spring/oil damper
Wheel travel
130.0 mm (5.12 in)

Rear suspension:

Type
Swingarm
Spring/shock absorber type
Coil spring/gas-oil damper
Wheel travel
120.0 mm (4.72 in)

Electrical system:

Ignition system
Transistorized coil ignition (digital)
Charging system
A C generator

Battery:

Model
GT14B-4
Voltage, capacity
12 V, 12.0 Ah

Headlight:

Bulb type

Halogen bulb

Bulb voltage, wattage x quantity:

Headlight

12 V, 60 W/55 W × 1

Tail/brake light

12 V, 5 W/21 W × 2

Front turn signal light

12 V, 21 W × 2

Rear turn signal light

12 V, 21 W × 2

Auxiliary light

12 V, 40 W × 1

Meter lighting

LED

Neutral indicator light

12 V, 17 W × 1

High beam indicator light

12 V, 17 W × 1

Oil level warning light

12 V, 17 W × 1

Turn signal indicator light

12 V, 17 W × 2

Fuses:

Main fuse

40 A

Headlight fuse

15 A

Signaling system fuse

10 A

Ignition fuse

15 A

Parking lighting fuse

10 A

Backup fuse

10 A

CONSUMER INFORMATION

Identification numbers

EAU26351

Record the key identification number, vehicle identification number and model label information in the spaces provided below for assistance when ordering spare parts from a Yamaha dealer or for reference in case the vehicle is stolen

KEY IDENTIFICATION NUMBER

VEHICLE IDENTIFICATION NUMBER:

MODEL LABEL INFORMATION.

Key identification number

EAU26381

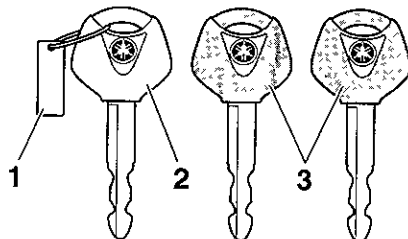

- 1 Key identification number
- 2 Code re-registering key (red bow)
- 3 Standard keys (black bow)

The key identification number is stamped into the key tag. Record this number in the space provided and use it for reference when ordering a new key.

Vehicle identification number

EAU26400

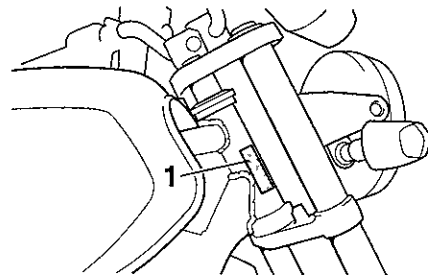

- 1 Vehicle identification number

The vehicle identification number is stamped into the steering head pipe. Record this number in the space provided.

NOTE:

The vehicle identification number is used to identify your motorcycle and may be used to register your motorcycle with the licensing authority in your area.

EAU26480

EAU26570

Model label

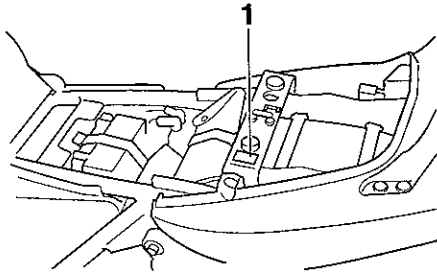

1 Model label

The model label is affixed to the frame under the seat (See page 3-14.) Record the information on this label in the space provided. This information will be needed when ordering spare parts from a Yamaha dealer.

Motorcycle noise regulation (for Australia)

TAMPERING WITH NOISE CONTROL SYSTEM PROHIBITED:

Owners are warned that the law may prohibit:

- a. The removal or rendering inoperative by any person other than for purposes of maintenance, repair or replacement, of any device or element of design incorporated into any new vehicle for the purpose of noise control prior to its sale or delivery to the ultimate purchaser or while it is in use; and
- b. The use of the vehicle after such device or element of design has been removed or rendered inoperative by any person.

INDEX

- A**
Air filter element, cleaning 6-10
Auxiliary light bulb, replacing 6-31
- B**
Battery 6-26
Brake and clutch fluid levels, checking 6-18
Brake and clutch fluids, changing 6-19
Brake and clutch levers, checking and lubricating 6-23
Brake and shift pedals, checking and lubricating 6-22
Brake lever 3-9
Brake pedal 3-10
Brake pedal position, adjusting 6-16
- C**
Cables, checking and lubricating 6-22
Carburetors, adjusting 6-11
Care 7-1
Catalytic converter 3-12
Centerstand and sidestand, checking and lubricating 6-24
Clutch lever 3-8
Clutch lever free play 6-16
- D**
Dimmer switch 3-7
Drive chain, lubricating 6-21
Drive chain slack 6-20
- E**
Engine break-in 5-3
Engine idling speed 6-12
Engine oil and oil filter element 6-8
Engine, starting a warm 5-2
Engine stop switch 3-8
- F**
Front and rear brake pads, checking 6-17
Front fork, adjusting 3-15
Front fork, checking 6-24
Fuel 3-11
Fuel cock 3-12
Fuel consumption, tips for reducing 5-3
Fuel tank cap 3-10
Fuses, replacing 6-27
- H**
Handlebar switches 3-7
Hazard switch 3-8
Headlight bulb, replacing 6-28
Helmet holder 3-14
High beam indicator light 3-4
Horn switch 3-8
- I**
Identification numbers 9-1
Ignition circuit cut-off system 3-18
Immobilizer system 3-1
Immobilizer system indicator light 3-4
Indicator and warning lights 3-3
- K**
Key identification number 9-1
- L**
Labels, location of 1-5
Luggage strap holders 3-17
- M**
Main switch/steering lock 3-2
Model label 9-2
Multi-function display 3-6
- N**
Neutral indicator light 3-3
Noise regulation (for Australia) 9-2
- O**
Oil level warning light 3-4
- P**
Panels, removing and installing 6-5
Parking 5-4
Part locations 2-1
Pass switch 3-7
Periodic maintenance and lubrication chart 6-2
Pre-operation check list 4-2
- R**
Rear brake light switch, adjusting 6-17
- S**
Safety information 1-1
Seat 3-14
Self-diagnosis device 3-5
Shifting 5-2
Shift pedal 3-9
Shock absorber assemblies, adjusting 3-16
Sidestand 3-18
Spark plugs, checking 6-7
Specifications 8-1
Speedometer 3-5
Starter (choke) lever 3-13
Starting and warming up a cold engine 5-1
Start switch 3-8
Steering, checking 6-25
Storage 7-3
Storage compartment 3-15
- T**
Tachometer 3-5
Tail/brake light bulb, replacing 6-30

INDEX

Throttle cable free play, adjusting	6-12
Throttle grip and cable, checking and lubricating	6-22
Tires	6-13
Tool kit	6-1
Troubleshooting	6-34
Troubleshooting chart	6-35
Turn signal indicator lights	3-3
Turn signal light bulb, replacing	6-30
Turn signal switch	3-7

V

Valve clearance, adjusting	6-13
Vehicle identification number ..	9-1

W

Wheel bearings, checking	6-26
Wheel (front)	6-31
Wheel (rear)	6-33
Wheels	6-15







1000

1000

1000

1000

1000

1000

1000

1000

1000

1000



YAMAHA MOTOR CO., LTD

PRINTED ON RECYCLED PAPER

PRINTED IN JAPAN
2003 11-0 3×1 CR
(E)